



Telephone Line Emulator



User's Manual for

Model TLE-A-01 and Software Modules:

TLE-ADV (Advanced Emulation)

TLE-INTL (International)

TLE-ICID (International Caller ID)



TELTONE CORPORATION END USER SOFTWARE LICENSE AGREEMENT

YOU SHOULD CAREFULLY READ THE FOLLOWING TERMS AND CONDITIONS BEFORE USING THE PRODUCT. USING THE PRODUCT INDICATES YOUR ACCEPTANCE OF THESE TERMS AND CONDITIONS. IF YOU DO NOT AGREE WITH THEM, YOU SHOULD PROMPTLY RETURN THE PRODUCT UNUSED AND YOUR MONEY WILL BE REFUNDED.

You may install the software contained on the diskette only on the hardware provided with the product. You may not copy the software, download the software from the product or in any way reproduce the software, in whole or in part. Title and full ownership rights to the software shall remain the sole property of TELTONE, and you shall acquire no rights in the software other than to use it with the hardware on which the software is installed. The software constitutes valuable proprietary assets of TELTONE, embodying substantial creative efforts and significant expenditures of time and money. You hereby agree to observe complete confidentiality with respect to the software. You agree not to alter or remove TELTONE'S proprietary and copyright notices from the software. You agree not to attempt to disassemble, decompile or otherwise reverse-engineer the software. You agree that in the event of an unauthorized reproduction, transfer or disclosure of any part of or all of the software, TELTONE will not have an adequate remedy at law, and therefore injunctive or other equitable relief will be appropriate to restrain such reproduction transfer or disclosure, threatened or actual.

COPYRIGHT. The enclosed Software is owned by Teltone Corporation and is protected by copyright law. You must treat the Software like any other copyrighted material (e.g., a book or musical recording) provided that you may either (a) make one copy of the Software for backup or archival purposes, or (b) transfer the Software to a single hard disk provided you keep the original solely for backup or archival purposes.

US GOVERNMENT RESTRICTED RIGHTS. This Product is provided with RESTRICTED RIGHTS. Use, duplication, or disclosure by the Government is subject to restrictions as set forth in subparagraph (c)(1)(ii) of The Rights in Technical Data and Computer Software clause at DFARS 252.227-7013 or subparagraphs (c)(1) and (2) of The Commercial Computer Software - Restricted Rights at 48 CFR 52.227-19, as applicable. Manufacturer is Teltone Corporation, Bothell, Washington, USA.

Technical Revision Notice

For revisions made to this manual after its release, please refer to the README.TXT file included with your TLE software. Changes noted in the README will be incorporated into the next revision of this manual. For the latest version of the TLE software, please visit Teltone's website at www.teltone.com.

Copyright Notice

Copyright © 1997 - 2002 Teltone Corporation
All Rights Reserved

Trademarks

Teltone is registered trademarks of Teltone Corporation.
Windows is a registered trademark of Microsoft Corporation.
Other company and product names may be trademarks or registered trademarks of their respective owners.

Teltone Corporation

Customer Service: 425-951-3388
Technical Support: 425-951-3390
Fax: 425-487-2288
Email: info@teltone.com
Website: www.teltone.com

Contents

Overview	1
Standard Unit Features (TLE-BASE)	1
Options	1
International Software Module (TLE-INTL).....	1
International Caller ID Software Module (TLE-ICID)	2
Advanced Emulation Software Module (TLE-ADV).....	2
Automated Test Software Module (TLE-TEST).....	2
TLE Front and Rear Panels	3
Getting Started	4
Check your TLE Package	4
Product Registration	4
Setting up the TLE.....	5
Power up the TLE	5
Installing the TLE Configuration Software.....	5
TLE Operation	6
Basic Calling Operation	9
Configuring the TLE	10
Main TLE Screen	11
Copy Configurations	12
Operational Screens.....	14
Audio Line Monitor.....	14
Busy Tone.....	15
Call Waiting.....	16
Caller ID - Visual Message Waiting	18
Advanced Screen Telephony	22
DC Signaling.....	22
Dial Tone	24
Loop Parameters	25
Miscellaneous	26
Phone Numbers	28
Port Configuration.....	30
Reorder.....	31
Ringing.....	32
Special Information Tones/Number Unobtainable Tone	33
Voice Messages	34
References	35
Advanced Emulation Software Module (TLE-ADV)	36
Impairments	36
Metering Tones	37
Signal Level Measurement	38
International Software Module (TLE-INTL).....	39
Rotary Dialing	39
References	39
Reset to Defaults	40
Country Screen.....	40
Importing Additional Countries.....	41
Call Waiting.....	42
Metering Tones.....	43
Special Information Tones/Number Unobtainable Tone	43
Loop Parameters (TLE-INTL)	45
Country Default Settings.....	45
Australia Defaults	46
Austria Defaults	47
Belgium Defaults	48
Brazil Defaults	49
China Defaults.....	50
Denmark Defaults	51
Finland Defaults	52
France Defaults.....	53

Contents (Continued)

Germany Defaults	54
Greece Defaults	55
India Defaults	56
Ireland Defaults	57
Italy Defaults	58
Japan Defaults	59
Korea Defaults	60
Netherlands Defaults.....	61
Norway Defaults.....	62
Singapore Defaults.....	63
Spain Defaults.....	64
Sweden Defaults.....	65
Switzerland Defaults	66
UK Defaults.....	67
US/Canada defaults.....	68
International Caller ID Software Module (TLE-ICID).....	69
Introduction.....	69
Overview - TLE-ICID.....	69
Details of Operation	70
Caller ID Timing Parameters.....	73
Programming	74
Caller ID and Call Waiting Modes	74
Caller ID and CIDCW Components and Sequence.....	76
Caller ID Miscellaneous Parameters.....	80
Phone Number Prefix and Group Selections	81
Caller ID and Call Waiting Tones	83
DTMF CID Parameters	84
Timings	86
Australia Defaults.....	90
France Defaults	92
Germany Defaults.....	94
Netherlands Defaults	96
Singapore Defaults.....	97
Sweden Defaults.....	98
UK Defaults.....	99
US/Canada Defaults	101
References	102
Automated Test Software Module (TLE-TEST).....	104
Automated Test Screen	104
Revision History	106
Troubleshooting.....	110
Errors on Power-up.....	110
Informational and Error Messages.....	111
Telephone Wiring Variants.....	114
Warranty and Service.....	116
Warranty Information	116
Return Procedures.....	116
Technical Assistance	116
Maintenance	116
Ordering Information	117
Technical Specifications.....	118
Appendix: Glossary	122
Index	127

IMPORTANT USER SAFETY INSTRUCTIONS

When using your equipment, basic safety precautions should always be followed to reduce the risk of fire, electric shock, and injury to persons, including the following:

1. Read and understand all instructions.
2. Follow all warnings and instructions marked on the product.
3. This product should be operated only from the type of power source indicated on the marking label. If you are not sure of the type of power supply, consult your dealer or local power company. Product designed for indoor use only.
4. To reduce the risk of electric shock, do not disassemble this product, but take it to a qualified serviceman when some service or repair work is required. Opening or removing covers may expose you to dangerous voltages or other risks. Incorrect reassembly can cause electric shock when the appliance is subsequently used.
5. If the product does not operate normally by following the operating instructions, or if the product has been dropped or the cabinet has been damaged, or if the product exhibits a distinct change in performance; refer servicing to qualified service personnel.
6. If this product is used in a manner other than specified in this manual, the protection provided by the product may be impaired.
7. The IEC 320 connector (power input) is the main power disconnect point, for the purpose of removing power from the unit. Pull the power cord away from the connector to assure power disconnect.
8. Adequate air flow must be maintained in order for the unit to operate correctly. Do not wrap the unit in blankets, paper, or other material that may impede ventilation.



CAUTION: THIS PRODUCT
CONTAINS ELECTROSTATIC
SENSITIVE DEVICES. USE
APPROPRIATE HANDLING
PROCEDURES.

REGULATORY COMPLIANCE

FCC Part 15 Class A Notice: This equipment has been tested and found to comply with the limits for a Class A digital device, pursuant to part 15 of the FCC Rules. These limits are designed to provide reasonable protection against harmful interference when the equipment is operated in a commercial environment. This equipment generates, uses, and can radiate radio frequency energy and, if not installed and used in accordance with the instruction manual, may cause harmful interference to radio communications. Operation of this equipment in a residential area is likely to cause harmful interference in which case the user will be required to correct the interference at his own expense.

The Installation Category (OVERVOLTAGE CATEGORY) for this device is II and it is designed to be safe under POLLUTION DEGREE 2, per IEC 1010-1: 1990 specifications.

Overview

The Teltone Telephone Line Emulator (TLE) is a user-configurable four-port analog telephone emulator, enabling simulation of many public switched telephone network (PSTN) conditions. The TLE is designed to work between 100 VAC and 240 VAC, enabling the TLE to be used worldwide. There is an International Software Module, an Advanced Simulation Software Module, an Automated Test Software Module, and an International Caller ID Software Module available. These options are designed to work individually with the basic TLE, or they can be mixed and matched depending on the user's requirements.

Standard Unit Features (TLE-BASE)

- Two user-selectable configuration settings
- 2 x 2 port or 4 port operation
- Vacuum Florescent Display for telephone port status information and other messages
- 600 or 900 ohm programmable input impedance
- Programmable ring frequency, ringback tones, voltage, and cadence
- Programmable loop current
- Programmable DC signaling (on/off-hook, flash, disconnect and line reversal)
- Programmable attenuation
- Three programmable numbers for each line
- Call Waiting, Visual Message Waiting, Stuttered Dial Tone
- Caller ID, SCWID (Caller ID in Call Waiting), and DSCWID (SCWID with Disposition)
- Programmable dial tone, busy tone, reorder tone, and special information tones (SIT)
- Five dial-up test tones plus one programmable test tone
- Calling Party Control, network delays, dialing mode, and other miscellaneous settings.
- Audio Messaging, Import WAV files from the PC, Multiple Message Playback
- 100 to 240 VAC power supply
- CE Mark Compliance
- Programming via Windows®-based software using a serial port
- 3.5 mm mono audio jack for monitoring audio

Options

International Software Module (TLE-INTL)

Basic unit features plus:

- 16 stored configuration settings which include:
 - 11 predefined Country specific settings
 - 5 preset North America settings
- 11 additional Country settings included
- Programmable 12 or 16 kHz metering tones
- Ability to call from one country configuration to another
- Complex impedances for Australia, Ireland, Germany, UK, and Switzerland

Telephone Line Emulator User's Manual

International Caller ID Software Module (TLE-ICID)

This module is an upgrade to TLE-INTL Software Module.

- Supports Multiple Caller ID formats
 - Bellcore
 - Bellcore Plus
 - ETSI FSK
 - ETSI DTMF
- Default Country Caller ID Configurations for:
 - Australia (Bellcore Plus)
 - France (ETSI FSK)
 - Germany (ETSI FSK)
 - Netherlands (ETSI DTMF)
 - Singapore (Bellcore Plus)
 - Sweden (ETSI DTMF)
 - United Kingdom (ETSI FSK)
 - USA/Canada (Bellcore)
- Many programmable parameters

Advanced Emulation Software Module (TLE-ADV)

Basic unit features plus:

- 16 stored configuration settings
- Echo emulation
- White noise emulation
- Satellite delay emulation
- Signal level measurement
- Enable Caller ID after every ring
- Enable/Disable DTMF detection (for pulse dial only applications)
- Metering tones

Automated Test Software Module (TLE-TEST)

Basic unit features plus:

- Control of TLE through serial port using API commands
- Ability to write customizable scripts for repetitive testing
- API definitions in both Visual Basic and C++ formats
- Programmable frequency sweep tone
- Status messages on front panel and through serial port
- Includes access to International and Advanced Emulation features
- Designed specifically for product development and production test applications
- International Caller ID features available with installation of TLE-INTL and TLE-ICID software modules

TLE Front and Rear Panels

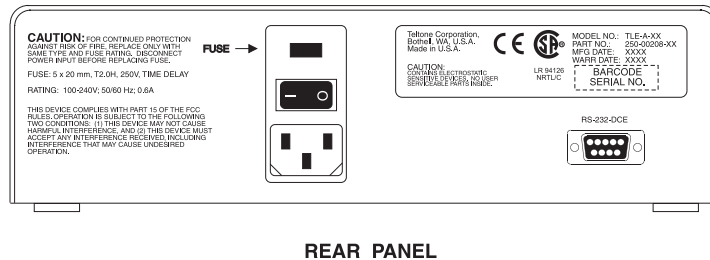
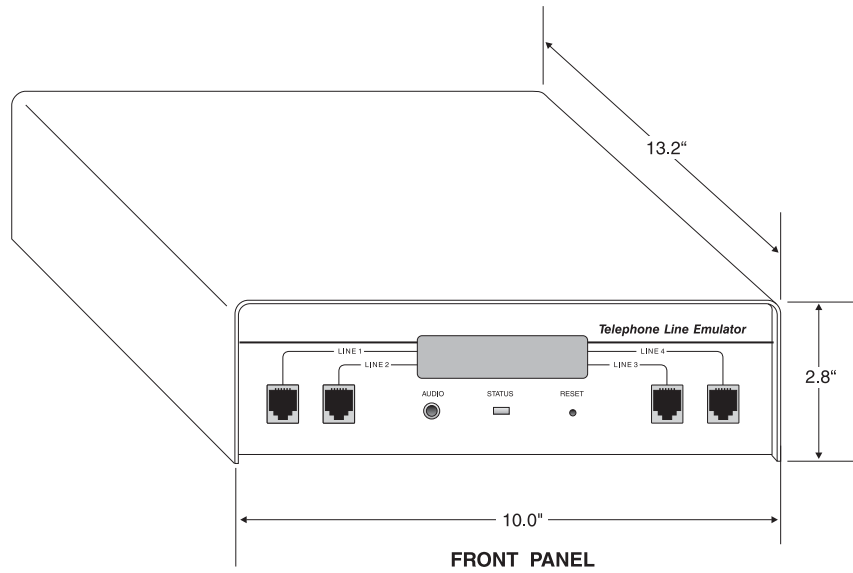

REAR PANEL

Figure 1. Telephone Line Emulator Front and Rear Panels

Getting Started

Check your TLE Package

Your basic package should include the following items:

- TLE-A-01 unit
- 110 VAC power cord for use in North America
- 9-pin male to 9-pin female RS-232 cable
- 9-pin male to 25-pin female adapter
- CD-ROM containing configuration software and User Manuals
- Product Registration Card

The following items may be included as options:

- International Software Module (TLE-INTL)
- International Caller ID Software Module (TLE-ICID) - Requires purchase of the International Software Module.
- Advanced Emulation Software Module (TLE-ADV)
- Automated Test Software Module (TLE-TEST)
- 7-foot modular telephone cable
- 25-foot modular telephone cable
- 9-pin male to 9-pin female RS-232 cable (1 supplied with each TLE unit)
- 9-pin male to 25-pin female adapter (1 supplied with each TLE unit)
- 7.5 foot 110 VAC power cord (1 supplied with each TLE unit)

If any of the items you ordered are missing or damaged, contact Teltone's Customer Service at 425-951-3388.

Product Registration

Please complete the Product Registration card and mail it to Teltone Corporation. This will place you on the mailing list for information regarding feature enhancements and product upgrade information.

Setting up the TLE

Power up the TLE

The TLE uses a universal power supply that operates from 100-240 VAC, 50/60 Hz. Connect AC power to the TLE, then turn the rear panel power switch to the ON position.



Grounding is assured by using the appropriate (approved) power cord.

The green Status LED on the front panel will indicate the state of the system. The LED should blink between mid-to-full brightness. If the LED fails to light, disconnect power immediately and contact Teltone Technical Support at 425-951-3390.

Adequate air flow must be maintained in order for the unit to operate correctly. Do not wrap the unit in blankets, paper, or other material that may impede ventilation.

Installing the TLE Configuration Software

The TLE Serial Port uses a standard RS-232 DCE interface. Using the cable provided, connect the TLE to a personal computer running a Windows-based operating system. (Optional with PC-software V2.00 or greater.)

Windows 95 or Later Versions

1. Insert the CD-Rom into the drive.
If the installation automatically starts, skip to step 4.
2. On the TaskBar, left click **START**, then **RUN**.
3. Type in your drive designator, followed by **Setup.exe**
example: **r:\setup.exe**
4. Follow the instructions on the screen to complete the installation.
5. Confirm that the correct communications port is configured. PC-Software V2.00 and greater will automatically display the TLE-Comm Port selection screen if the TLE is not connected or uses a port other than Comm1. Select the appropriate port and then **Detect**. The TLE software will test to see if your TLE is connected. The control leads status are shown at the bottom of the window. If the TLE is connected with the proper cable; all should be green. If not; CTS, DSR, and CD are normally red. Select **Cancel** if your TLE is not connected at this time. Select **OK** to complete the CommPort selection.

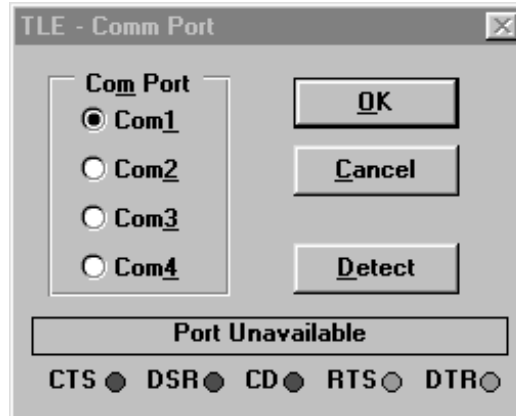

Figure 2. TLE - Comm Port Screen

Windows 3.1 and Windows 3.11 (Windows for Workgroups)

1. Insert the CD-Rom into the drive.
2. Using the Windows Program Manager, Select **File, Run**.
3. Type in your drive designator, followed by **Setup.exe**
example: **r:\setup.exe**
4. Follow the instructions on the screen to complete the installation.
5. Confirm that the correct communications port is configured. PC-Software V2.00 and greater will automatically display the TLE-Comm Port selection screen if the TLE is not connected or uses a port other than Comm1. Select the appropriate port and then **Detect**. The TLE software will test to see if your TLE is connected. The control leads status are shown at the bottom of the window. If the TLE is connected with the proper cable; all should be green. If not; CTS, DSR, and CD are normally red. Select **Cancel** if your TLE is not connected at this time. Select **OK** to complete the CommPort selection.

TLE Operation

The following call process flowchart will help to explain the basics of call setup and completion. More detailed explanations are included after the flowchart.

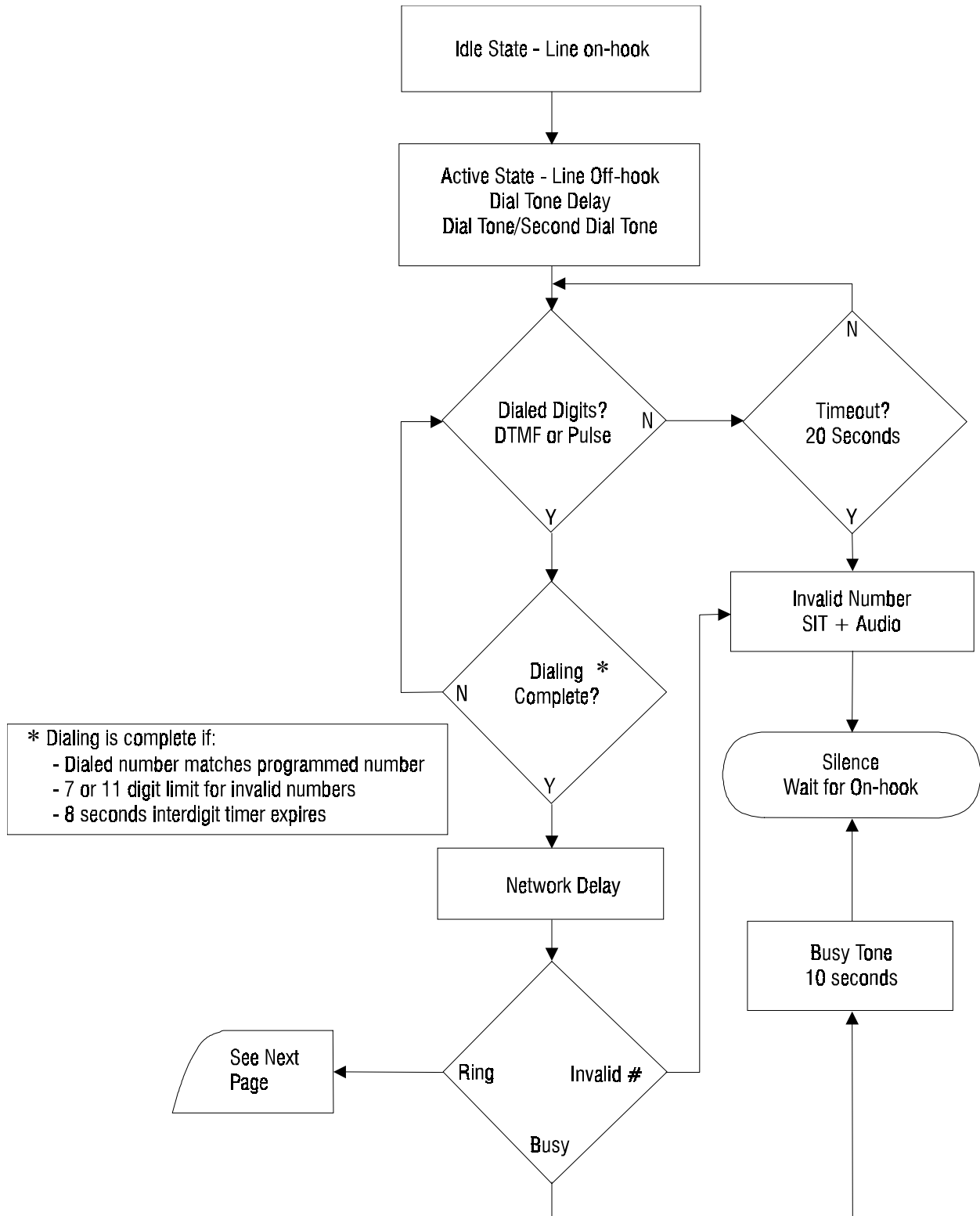

Figure 3. TLE Call Processing Flowchart (Part 1)

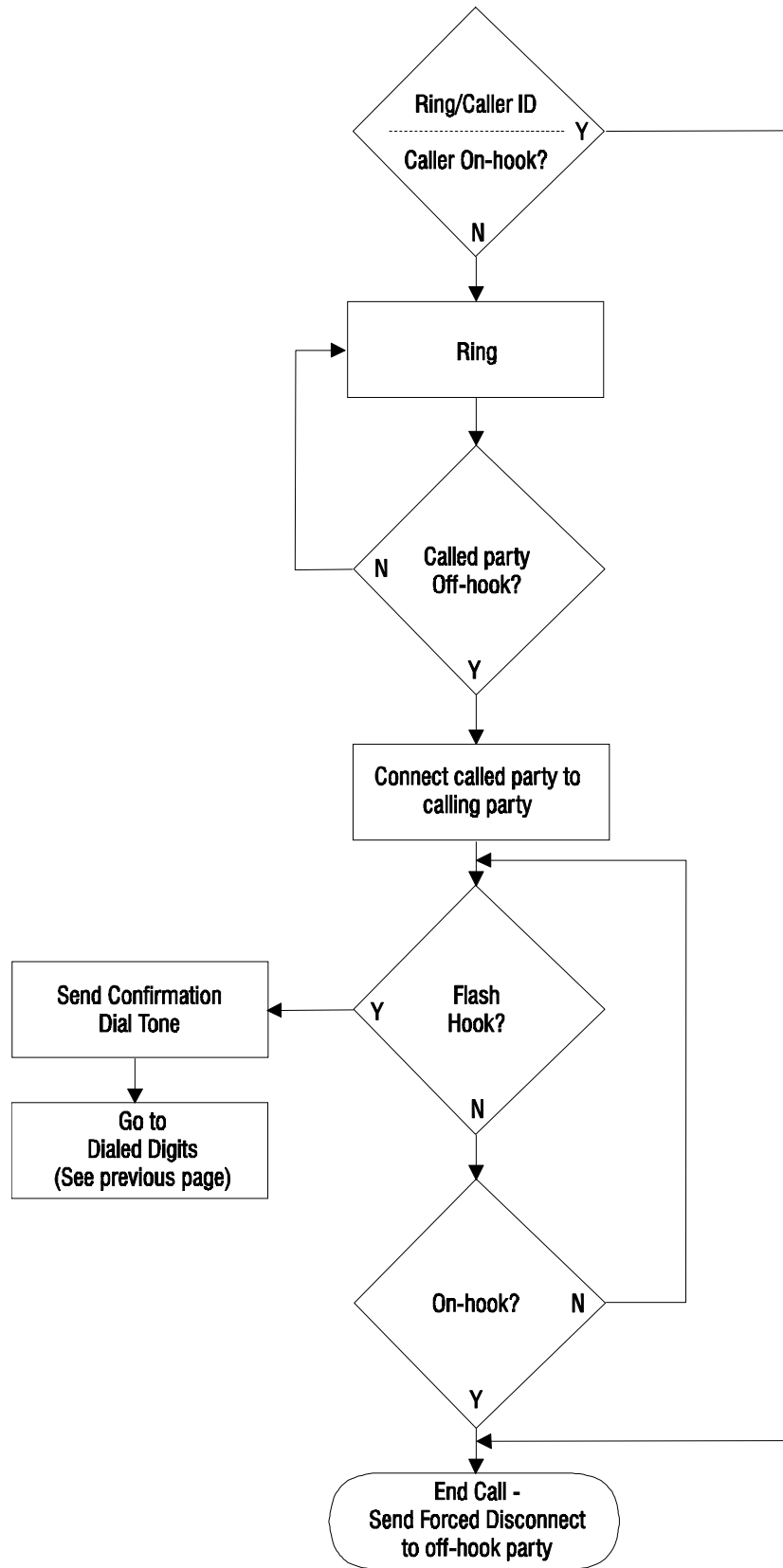

Figure 4. TLE Call Processing Flowchart (Part 2)

Basic Calling Operation

The Teltone TLE provides dial tone (Normal – default), or Ringdown (Hotline), or a quiet battery feed (Silent), when a device goes off-hook and draws sufficient loop current. When dialing is detected, DTMF or Pulse (aka Rotary dialing), dial tone stops. If an invalid sequence is dialed, the TLE will issue an Invalid Number Response of SIT + Audio (default), SIT repeating, Busy, Reorder, Ringback, Silence, or Audio. If a valid number is dialed, a Hunt Mode of Ring All (default), Ring 1st match, Ring 1st available, or Ring next, is invoked. Caller ID information is sent to the Called Party, along with Ringing, and Ringback tone is sent to the Calling Party. When the called line answers, a connection is established between the two parties.

During an existing call, another party may go off-hook and dial a number that matches one of the connected parties. If so, then a SAS (Call Waiting tone) + CAS (Caller ID tone) is issued to the called party. If the called party has a Caller ID box or phone that supports SCWID (aka Caller ID in Call Waiting), then the Caller ID information will be issued by the TLE. If the called party does not answer the waiting call, a repeat of the Call Waiting tone occurs ten seconds after the first. During an existing call, either party may wish to Transfer/Conference another party. To accomplish this, the originating party must generate a hook flash, after which the TLE will return a Confirmation Dial Tone, and the originating party will dial the number of a third party. After connecting to the third party, all three are brought together with another hook flash. Conference operation is dependent upon the setting of the Conference Type in the Miscellaneous Screen.

The end of a call uses Calling Party Control. If the Called Party hangs up, the connection may be re-established if they go off-hook before the Forced Disconnect Timer expires. If the Calling Party goes on-hook, or if the Forced Disconnect Timer expires, then a Forced Disconnect signal, a break in the loop current, is sent to the remaining party if they are off-hook. After a Forced Disconnect signal is sent, and the party remains off-hook, then Disconnect Treatment is invoked. The options include Dial Tone (default), Busy, Reorder, Silence, or an Audio message.

The TLE supports a few special dialing sequences. These include:

Special Caller ID	dial *67 + telephone number to send PRIVATE
	dial *87 + telephone number to send OUT OF AREA
	dial *88 + telephone number to send Checksum error
Speed Dialing	dial 1#, 2#, 3#, or 4# to access lines 1,2,3, or 4 respectively
Visual Message Waiting	dial *50 + telephone number to turn VMW ON
	dial *51 + telephone number to turn VMW OFF
DTMF Programming	dial **99##
Set Active Configuration	dial *xx#, where xx is the configuration #
Version Query	dial *99#, view display for versions

Special Telephone Numbers (programmable) include:

Audio Access Message	dial 411
Dial Tone (continuous)	83781 (TEST1)
Busy (continuous)	83782 (TEST2)
Reorder (continuous)	83783 (TEST3)
Ringback (continuous)	83784 (TEST4)
Special Test Tone (continuous)	83785 (TEST5)
Stuttered Dial Tone (continuous)	83786 (TEST6)

Configuring the TLE

Using the Configuration Software, different configurations can be saved to download to the TLE. A configuration contains all the programmable parameters of the TLE. The standard TLE (TLE-BASE) unit can have 2 different configurations, while the add-on software modules can have up to 16 different configurations.

The **Active Configuration** is the configuration that is being used by the TLE. Any configuration may be selected as the **Active Configuration** using the Configuration Software, or an ASCII command string via the serial port, or a DTMF dialing sequence from a device connected to a port. See below for more information.

A Configuration Set is a file name given to reference the configurations saved. Only one Configuration Set can be downloaded to the TLE, although multiple Configuration Sets can be saved on the PC.

Editing a configuration may be done off-line, or while connected to the TLE. While connected to the TLE, changes made are updated in the TLE by either selecting the **APPLY** or **OK** button on each screen. Using the **APPLY** button will implement the changes but keep the current screen to allow for any additional changes. Using the **OK** button will implement the changes, exit the screen and return to the Main screen. If the update is to the **Active Configuration**, every update will cause the display of the TLE to show "Initializing Configuration" and then "Active Configuration" and then the configuration number. The TLE must be in the idle state (all lines on-hook) for the update to occur. If the update is to a configuration that is not currently active, the TLE display will not change.

When the TLE_PC software is run, it will read the **Unit Name** and the **Active Configuration** of the TLE and display them on the Main screen of the software. If there is no TLE connected, the title bar will read **TLE_PC - No Unit Connected**. If there is a TLE connected and the Configuration of the TLE does not match the default configurations in the software, a screen will appear asking whether you want to query the TLE for its configuration settings. In addition, any time the TLE is initially connected, the software will automatically query the unit for firmware version information. If the software has an updated version, it will ask you if you want to download the new code.

Reset

On the front panel of the TLE there is a recessed button called **Reset**. Pressing this button for greater than 1 second once will display a prompt asking, "*Reset all configs? Press Reset = yes*". Pressing **Reset** a second time for greater than 1 second will reset the TLE configuration memory to the factory default settings with Configuration 1 active.

When the front panel **Reset** button is pressed, the unit will be reset to the US/Canada defaults for all configurations. The user must perform **Defaults** and **Send All** from the PC configuration software to reload the defaults for each individual country configuration.

Selecting Active Configuration using DTMF

All other ports must be on-hook and the dialing sequence is as follow: go off-hook, dial ****99##** to enter Programming Mode, then dial ***xx#**, where **xx** is the configuration number. For example, to select configuration 02, dial ***02#** and the TLE will respond with

a three beep confirmation tone (if enabled), and the display will show the new configuration following an initialization sequence. If an error in the entry occurs, the TLE will respond with a single beep error response.

Selecting Active Configuration using the serial port

The Active Configuration may be selected via the serial port with PC_TLE software 2.00 or greater. This is accomplished by setting up the serial port at 9600 baud, 8 data bits, 1 stop bit, no parity, hardware flow control, and sending an ASCII string to change the Active Configuration. The format of the message to the TLE is either:

:XX<cr> or,

:XX,YY<cr>

The TLE will respond with !OK if the command is accepted or !ERR if it is rejected.

:XX will set the active configuration from 01 to 16 for all 4 ports and :XX,YY will set the active configuration XX for ports 1 and 3 and YY for ports 2 and 4.

Note: Local echo of command characters is not provided by the TLE.

Main TLE Screen

The top section of the main TLE screen displays the **Active Configuration** Number, Name, and Date/Time it was created, if a TLE is connected. This field will be blank if no TLE is connected. It also shows the current **Configuration Set** Name and the Date/Time it was created. The **Set Active** button allows the user to choose the Active Configuration in the TLE.

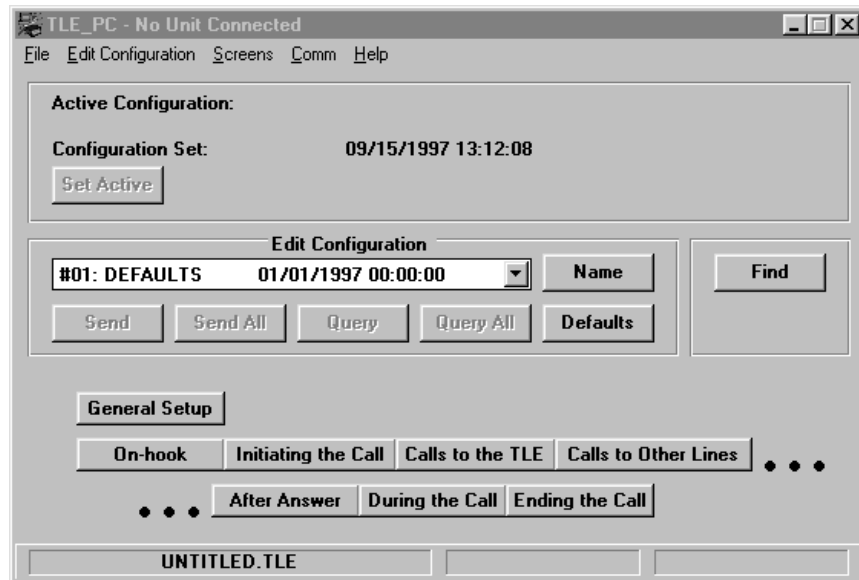

Figure 5. Main TLE Screen (No TLE Connected)

The middle section of the screen displays the Configuration being edited. The **Name** button allows the user to change the name of each configuration. The **Send** button sends the current configuration being edited to the TLE. The **Send All** button sends all of the

configurations in the Configuration Set to the TLE. The **Query** button will query the settings for the current configuration in the TLE. The **Query All** button will query all of the stored configurations in the TLE. The **Defaults** button will reset any Configuration under edit to the factory default settings.

The bottom section displays buttons that conform to the natural order of call placement and pressing any of these buttons will bring up windows with information regarding the operation of the TLE. Another method to use when changing the operation of the TLE is to use the **Screens** menu on the menu bar. All of the screens are displayed in alphabetical order. A **Find** button is also supplied to help with locating the parameter to be changed.

The bottom line of the **Main** screen will report three items:

- 1) The name of the saved file under edit.
- 2) If the Configuration Set under edit matches what is stored in the TLE, **Set=TLE** will be displayed. If the Configuration Set does not match, **Set<>TLE** will be displayed.
- 3) If the Configuration being edited matches the configuration stored in the TLE, **Configuration=TLE** will be displayed. If not, then **Configuration<>TLE** will be displayed.

The **Screens** menu is used to change the settings of the operational features of the TLE. These are broken into individual screens labeled as **Audio**, **Busy**, **Call Waiting**, **Caller ID**, **DC Signaling**, **Dial Tone**, **Loop Parameters**, **Miscellaneous**, **Phone Numbers**, **Port Configuration**, **Reorder**, **Ringing**, **Special Information Tones**, and **Voice Messages**. Other screens that are active if the TLE-INTL, TLE-ADV, or TLE-TEST software modules are purchased include **Country**, **Metering Tones**, **Impairments**, **Signal Level Measurement**, and **Automated Test**. The TLE-ICID Software Module combines Call Waiting and Caller ID into a single screen called **Caller ID/Call Waiting**.

Copy Configurations

The **Edit** menu is used to copy settings from one configuration to another, or to copy the settings from one Line to another by using the **Copy Configuration** and **Copy Line** commands found in the **Edit Configuration** menu.

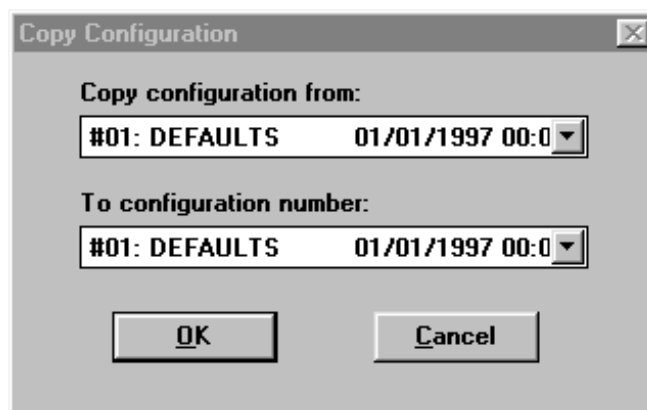

Figure 6. Copy Configuration Screen

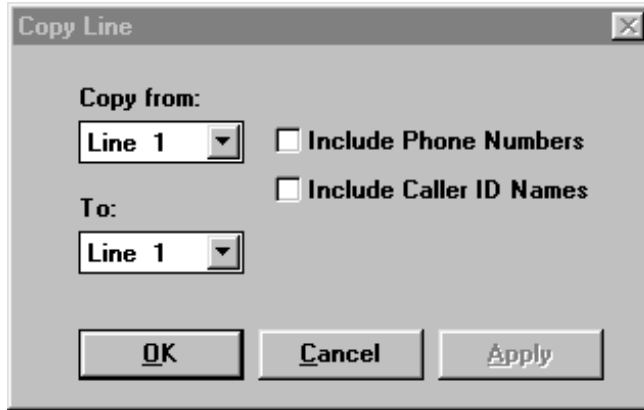

Figure 7. Copy Line Screen

Operational Screens

Audio Line Monitor

The Audio port on the front of the TLE is used to monitor the AC signals on any one of the lines of the TLE when this feature is enabled. Only one line may be monitored at a time. The audio line monitor port is a 3.5 mm miniature audio jack.

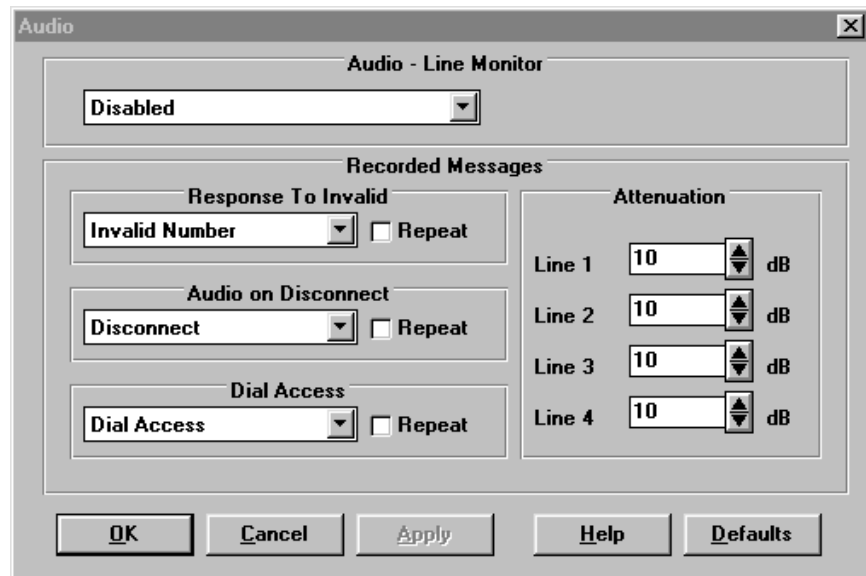

Figure 8. Audio Screen

Recorded Messages

The **Recorded Messages** portion of the **Audio** screen, together with the **Voice Messages** screen, allows the selection of recorded messages for playback. There are three conditions defined for playback: **Invalid** phone **Number** dialed, **Audio** message **on Disconnect**, and message for **Dial Access**. There are four messages which may be stored. The default names (see **Voice Messages** screen) are: **Invalid Number**, **Disconnect**, **Dial Access**, and **Alternate**. Any of these four names may be selected for the three conditions with the **Audio** screen.

When one of the conditions for playback occurs, the recorded message plays one time, followed by silence. If the **Repeat** selection is checked, the audio message will repeat continuously.

The TLE ships with one default message for each of the three conditions. These messages are stored in a mono 8 kHz, 8-bit μ -law WAV file format. Their names are: **Invalid.WAV**, **Hangup.WAV**, and **Dialacc.WAV**. The user may create new files using a sound card. Double clicking on the **File** field in the **Voice Messages** screen allows the selection of a new file. The TLE-PC software stores these in 0.5 seconds increments and displays the total file length on the screen. The sum

of all recorded messages must not exceed the total length for the audio memory (8 seconds).

Attenuation

Attenuation is the loss of signal level. Attenuation values refer to the amount of attenuation compared to the original recording.

Attenuation may be set from 0 dB to 60 dB in 1 dB increments.

Busy Tone

The Busy signal is an indication that the Called Line is off-hook and not available. Busy Tone has several variables, including: **single tone** or **dual tone**, **output level**, and a **simple** or **complex cadence**.

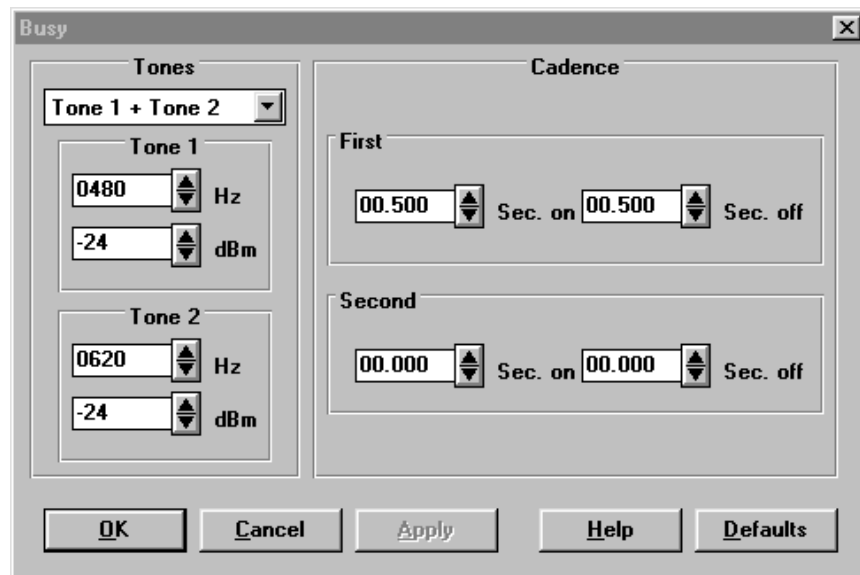

Figure 9. Busy Screen

Busy Tone Levels and Frequencies

Busy Tones may be single or dual frequencies with individually adjustable amplitudes. With a selection of Single Tone the system will only generate the first tone. With a selection of Tone 1 + Tone 2 the system will generate both tones with the specified frequencies and amplitudes. Purchase of the TLE-INTL Software Module adds the selection of Tone 1 x Tone 2. The system will generate Tone 1 modulation by Tone 2. In this implementation only the fundamental and upper side tone are generated, both at the amplitude programmed for Tone 1.

For each tone, the frequency range may be set from 10 Hz to 1000 Hz in 1 Hz increments.

Output level may be set from -6 dBm to -60 dBm per tone in 1dB increments.

Busy Tone Cadence

First Cadence on time may be set from 100 mS to 2000 mS in 5 mS increments.

First Cadence off time may be set from 100 mS to 2000 mS in 5 mS increments.

Second Cadence on or off time may be set from 0 mS to 5000 mS in 5 mS increments, or may be set to 0 if only the **First Cadence** values are to be utilized.

If the **Second Cadence** values are 0, the unit will repeat with the **First Cadence** values. If the **Second Cadence** values are programmed, the unit will repeat after going through all four time values.

Call Waiting

The Call Waiting signal (a.k.a. SAS Tone, Subscriber Alerting Sequence) is an indication that there is a calling party waiting for the called party to become available. The calling party hears normal ringing and the called party hears a Call Waiting Tone that is repeated once, 10 seconds after the first occurrence. The called party answers a Call Waiting by either generating a FLASH, which places the existing caller on hold, or by hanging up on the existing caller, after which the telephone will begin to ring again with the waiting caller. In some Central Offices, a waiting caller is announced with a Normal single tone if the call is local, and a Distinctive two tone sequence if the caller is calling from long distance.

Call Waiting With Caller ID Enabled (SCWID or CIDCW)

SCWID (Spontaneous Call Waiting with Caller ID) also known as CIDCW (Caller ID in Call Waiting) is a function that sends the FSK data (Caller ID) after a Call Waiting Tone. This data transmission burst is typically sent to a specially configured telephone or an adjunct device that mutes the line to the local caller for the duration of the FSK burst. The format of the message is always multiple message format, that is, the Name and Number are sent to the called party. This feature is invoked whenever a third party places a call to an existing call, if Caller ID is enabled and Cancel Call Waiting has not been enabled. When a third party is calling, the called line will be momentarily isolated and will hear a Call Waiting Tone (SAS tone), followed by a CAS tone to alert the Caller ID phone or adjunct. If the Caller ID phone or adjunct issues a DTMF "D" (from non-ADSI CPE) or a DTMF "A" (from ADSI CPE) acknowledgement tone, the FSK sequence is sent down the line for Caller Identification. The called party may then ignore the Call Waiting, or generate a flash to place the first caller on hold, and answer the Call Waiting. If the Called Party ignores the first Call Waiting alerting sequence, it will be repeated once, ten seconds later. If the called party answers the Call Waiting, they are allowed to alternate between callers using the flash function. If one party hangs up, the remaining parties are automatically connected.

Call Waiting with Caller ID Disabled

A user may want to have the TLE generate just the Call Waiting Tone (SAS tone) without Caller ID or CAS tone. To have the TLE perform in this manner, go to the Caller ID Screen and disable Caller ID for the line in use.

Cancel Call Waiting

The Call Waiting tone may be disabled on a per-call basis by dialing ***70** or **70#**, TLE Response - Confirmation Dial Tone. (See Dial Tone screen.) Call Waiting will be reset and enabled after the line is placed on-hook.

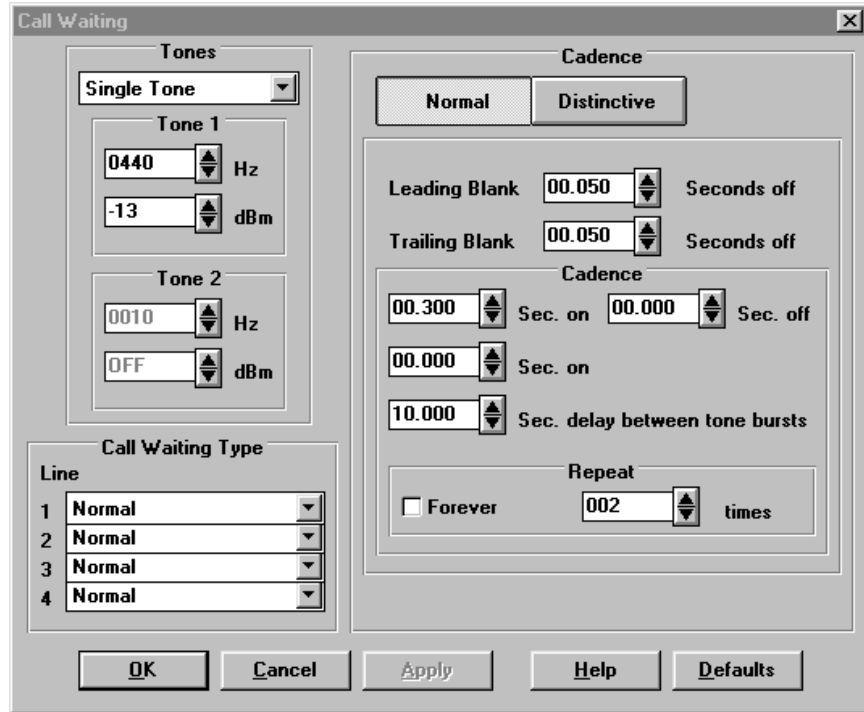

Figure 10. Call Waiting Screen

The Call Waiting signal has several variables, including: **Disabled, Single Tone or Dual Tone, Type of Call Waiting Signal, and Cadence.**

Call Waiting Tone Levels and Frequencies

Call Waiting Tones may be single or dual frequencies with individually adjustable amplitudes. With a selection of Single Tone the system will only generate the first tone. With a selection of Tone 1 + Tone 2 the system will generate both tones with the specified frequencies and amplitudes. Purchase of the International Module adds the selection of Tone 1 x Tone 2. The system will generate Tone 1 modulation by Tone 2. In this implementation only the fundamental and upper side tone are generated, both at the amplitude programmed for Tone 1.

For each tone, the frequency range may be set from 10 Hz to 1800 Hz in 1 Hz increments.

Output Level may be set from -6 dBm to -60 dBm per tone in 1 dB increments.

Call Waiting Type

Call Waiting Type may be programmed for each Line. Options are **Disabled, Normal,** and **Normal & Distinctive.**

Call Waiting Cadence

Two Cadences are available: **Normal** and **Distinctive.**

Both **Cadence** on times may be set from 0 mS to 1500 mS in 5 mS increments.

Cadence off time may be set from 0 mS to 1500 mS in 5 mS increments.

Leading Blank, or the delay before the call waiting tone is sent, may be set from 5 to 100 mS off in 5 mS increments. (Default = 50 mS.)

Trailing Blank, or the delay after the call waiting tone is sent, may be set from 20 mS to 100 mS off in 5 mS increments.

The Leading Blank time is the time from when the existing call is muted and the Call Waiting starts. The Trailing Blank time is the time from when the Call Waiting stops and the existing call is reconnected.

Caller ID - Visual Message Waiting

The Caller ID signal is an FSK signal sent at 1200 baud to alert the called party of the identity of the calling party. This may consist of the telephone number only, (Single Message Format), or a Name and Number (Multiple Message Format). The transmission also includes a Date and Time, and issues a checksum at the end for error correction. Special sequences include Out of Area *87 (indicates no available information for the caller), Private *67 (Blocked Call) and an error message *88 (checksum error) when a special prefix code is dialed before the normal telephone number. For testing and development purposes, there is a special mode where the Caller ID is sent after every ring. (TLE-ADV only.)

Visual Message Waiting is an FSK signal sent at 1200 baud to turn on a visual indicator on an adjunct or Caller ID phone. This signal is sent during an on-hook state after an open switch interval.

Turn ON the Visual Message Waiting Indicator using the following dial sequence;

Dial *50 + "Called Telephone Number"

Turn OFF the Visual Message Waiting Indicator using the following dial sequence;

Dial *51 + "Called Telephone Number"

Example: A Caller ID adjunct or display phone is connected to Line 2. From a telephone connected to any other line, go off-hook and dial *50 102. The display for the called line will indicate VMW sent during the time when FSK is generated after the Open Switch Interval.

Stuttered Dial Tone is issued to the called line until VMWI OFF is invoked or the Dial Access Audio Message is dialed. Default is 411.

Note: The TLE-ICID Software Module is available as an upgrade to the TLE-INTL Software Module. This upgrade module combines the Call Waiting screen and the Caller ID screen. The TLE-INTL software will allow Caller ID to be enabled for other countries but it conforms to the Bellcore (USA/Canada) standards.

Line	Caller ID Mode	Select Name & Number	Group 1 Name	Visual Message Mode
1	Multiple Message	Group 1	ANDERSON ALLEN	Single Message
2	Multiple Message	Group 1	JONES JENNIFER	Single Message
3	Multiple Message	Group 1	SMITH SHARON	Single Message
4	Multiple Message	Group 1	MACDONALD MIKE	Single Message

Figure 11. Caller - ID Visual Message Waiting Screen 1

Caller ID Time

This may be set either by the user or can be read from the PC clock. The TLE maintains a real time clock only when power is on. Upon power up the date and time start at the time as set by this field.

Caller ID After Every Ring

Caller ID After Every Ring is a feature that will send the FSK sequence after every Power Ring Cycle. The Caller ID will be sent only if the minimum off time criteria is met. (TLE-ADV and TLE-TEST Software Modules only.)

Minimum Ring Off Time

By default, the TLE must see a minimum of 3 seconds in the off portion of the Ring Cadence, before Caller ID is sent. By programming this field to a shorter time, the user can force a transmission during shorter **Ring Off Time**. The user must be aware that, for shorter times, the entire FSK data burst may not be complete before the next ring cycle.

The **Minimum Ring Off Time** can be set from 0 seconds to 10 seconds in 5 mS increments. Default is 3 seconds.

Caller ID Sequence

Caller ID Sequence is a feature that allows a user to select the sequence and information that is sent with each Caller ID block using the Multiple Message Format. This is useful to ensure that CPE devices may receive this data regardless of the order of the messages.

If a ***67** prefix is dialed prior to the number, the Private sequence will be used.

If a ***87** prefix is dialed prior to the number, the Out of Area sequence will be used.

If a ***88** prefix is dialed prior to the number a checksum error is generated.

Otherwise, the Normal sequence will be used.

Caller ID Mode

This feature allows the selection of the Caller ID Mode for each Line. The options include Multiple Message format (default), Single Message format, or Disabled.

Select Name & Number

This feature allows the selection of one of three different Groups of Names and Numbers (see Phone Numbers). The Names for Group 1 are programmable for up to 16 characters. The Names for Group 2 and 3 are fixed. The defaults for the Names follow this paragraph.

Group 1 - Programmable names, uses Group 1 telephone numbers

Line 1 = ANDERSON ALLEN

Line 2 = JONES JENNIFER

Line 3 = SMITH SHARON

Line 4 = MACDONALD MIKE

Fixed names for Group 2, uses Group 2 telephone numbers

Line 1 = CLINTON BOB

Line 2 = REAGAN RICK

Line 3 = CARTER JOHNNY

Line 4 = FORD GARY

Fixed names for Group 3, uses Group 3 telephone numbers

Line 1 = MONTANA JIM

Line 2 = MARINO DON

Line 3 = AIKMAN TOM

Line 4 = KELLY JOHN

Group 1 Name

The **Group 1 Name** is programmable up to 16 characters. This is the name that is sent to the Called Line from the Calling Line when Multiple Message format is used.

Visual Message Mode

This feature allows the selection of the Visual Message Mode for each Line. The options include Multiple Message format (default), Single Message format, or Disabled.

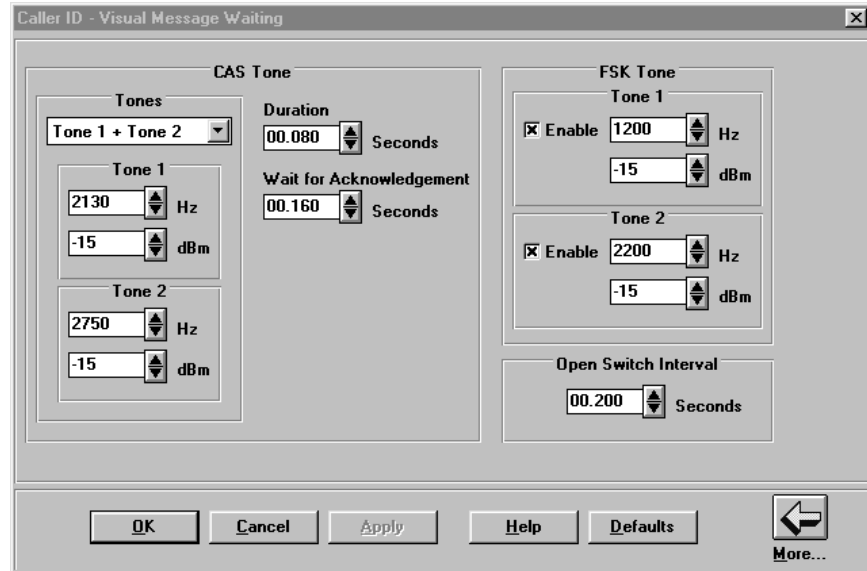

Figure 12. Caller ID Visual Message Waiting Screen 2

CAS Tone

CAS Tone is a CPE Alerting Signal; a Bellcore term for a tone used to alert CPE equipment of Call Waiting, asking for ACKnowledgement prior to sending Caller ID. The CAS Tone has several variables, including: **Disabled**, **Single Tone** or **Dual Tone**, **Duration**, and Time to **Wait for Acknowledgement**.

With a selection of Single Tone the system will only generate the first tone. With a selection of Tone 1 + Tone 2 the system will generate both tones with the specified frequencies and amplitudes. Purchase of the International Module adds the selection of Tone 1 x Tone 2. The system will generate Tone 1 modulation by Tone 2. In this implementation only the fundamental and upper side tone are generated, both at the amplitude programmed for Tone 1.

Frequency for Tone 1 and Tone 2 may be set from 10 Hz to 3000 Hz in 1 Hz increments and -6 dBm to -60 dBm in 1 dBm increments.

Duration may be set from 70 mS to 90 mS in 5 mS increments.

After the TLE sends the CAS signal it waits a certain time for a DTMF ACKnowledgement signal from the CPE device. If it sees this, it sends the FSK data. This **Wait for Acknowledgement** time may be varied to ensure that CPE devices are responding within the proper time window. **Wait for Acknowledgement** may be set from 100 mS to 300 mS in 5 mS increments.

FSK Tone

The **FSK** (Frequency Shift Key) **Tones** are programmable in both frequency and signal level. The mark (1) tone is the lower of the two tones and is programmable from 1100 Hz to 1400 Hz. The space (0) tone is the upper tone and is programmable from 2000 Hz to 2300 Hz. Both tone levels may be set from -10 dBm to -60 dBm in 1 dB increments.

Open Switch Interval

The Open Switch Interval is a form of DC signaling, sent during an on-hook state, prior to Visual Message Waiting. During this time, the -48 VDC is momentarily removed. **Open Switch Interval** may be set from 0 seconds to 5 seconds in 5 mS increments.

Advanced Screen Telephony

ADSI, also known as Advanced Screen Telephony, a Type III Caller ID sequence, is supported in the TLE using a special ADSI test number ****99****, which performs a script download from the TLE. Three data bursts are sent from the TLE, shown in the display as ADSI_ack1, ADSI_ack2, and ADSI_ack3 to load a script called "Call Management".

This new service provides a limited script that will display **"New Call From"** and **"Caller ID"**. After answer, the display changes to **"Talking To"** and **"Caller ID"** and a button labeled **"Don't interrupt"**. If the button is pressed, the CPE will perform a flash; dial ***70** to disable Call Waiting and then displays **"Call Waiting OFF"**.

When the CPE receives a Caller ID during a call, the display will show **"New Call From"** and **"Caller ID"**. The button selection will change to **"Connect New Call"**. If this button is pressed, the original caller is placed **"On Hold"** and the button changes to **"Reconnect 1st Call"**.

DC Signaling

DC Signaling changes polarity or loop current characteristics of the line. These include **On/Off-hook Detect Times**, **Hook Flash Detect Time**, **Line Reversal**, and **Forced Disconnect Length and Delay**.

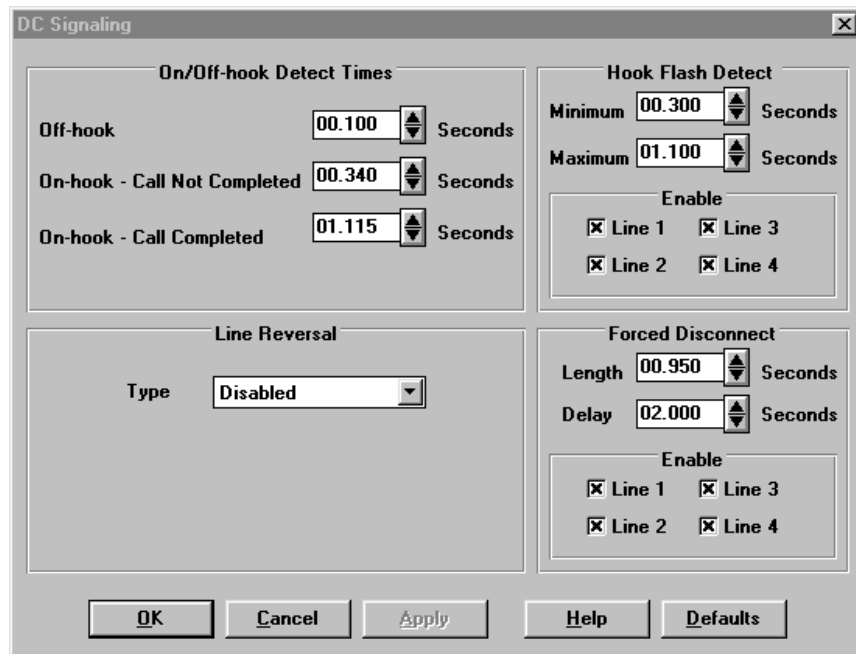

Figure 13. DC Signaling Screen

On/Off-hook Detect Times

Off-hook Detect is the minimum duration that loop current must occur for a valid off-hook condition. On-hook Detect is broken into two values. If a call has not been completed, for example a busy number has been dialed, a short on-hook time is used. If a call has been completed, a long on-hook time is used. This allows hook flashes to be recognized. If hook flashes have been disabled, the TLE always uses the **Call Not Completed** timer value for on-hook detection.

Off-hook Detect Times may be set from 100 to 3000 mS in 5 mS increments. **On-hook Detect** may be set from 100 to 3000 mS in 5 mS increments.

Note: **On-hook** time must exceed **Hook Flash** time.

Hook Flash Detect

Hook Flash, a.k.a. FLASH and Switch Hook Flash, is a loss of loop current for a specific duration that is used to request special features, such as Transfer, Conference, and Hold.

Hook Flash Detect Minimum and **Maximum** can be set from 75 mS to 1200 mS in 5 mS increments.

Each line may be enabled or disabled for **Hook Flash Detect**.

Line Reversal

A line reversal is a signal that changes the polarity of the battery on the line subject to certain conditions. These conditions may include Called Party Answer, Call Termination, and others. **Line Reversal Type** is available as **Disabled**, **Simple** or **Complex**. (The default is reversal disabled. This programming will apply to all lines.) When the unit is programmed for **Simple Line Reversal** on an originating call, a line will perform a reversal just prior to issuing dial tone. It will then remain at that state until it goes back on-hook, in which case another reversal will be performed. For an incoming call a line will perform a line reversal after it goes off-hook in response to ringing.

When the unit is programmed for **Complex Line Reversal** on an originating call, a line will perform a momentary reversal just prior to issuing dial tone. The duration of the reversal is programmable, and may range from 50 mS to 100 mS in 5 mS increments. On an incoming and outgoing call a permanent line reversal will be performed at call completion.

Forced Disconnect

Forced Disconnect is a method used by the telephone company to clear a line. When the called party goes on-hook, the Central Office returns an open (that is, drops loop current) of at least 800 mS to the calling party. The TLE emulates Calling Party Control, in which, if the calling party goes on-hook the called party receives a Forced Disconnect within 2 seconds. If the called party goes on-hook, the calling party receives a Forced Disconnect which may occur some time greater than 2 seconds later. This timer is programmable, up to 30 seconds. The actual **Length** of the **Forced Disconnect** is also programmable with the default being 850 mS.

Forced Disconnect Length may be set from 0 to 2 seconds in 5 mS increments.

Forced Disconnect Delay may be set from 1.2 to 30 seconds in 5 mS increments.

This feature may be enabled or disabled for each line.

Dial Tone

Dial Tone is the audible signal issued to a calling party when the Central Office is ready to receive digits. The TLE issues a Second Dial Tone after a series of digits are dialed to emulate operation of a PABX or other switch platforms. (See Revert to Dial Tone phone number.) Other types of dial tones include **Recall** Dial Tone (an interrupted Dial Tone, a.k.a. Stuttered Dial Tone, indicating recognition of a FLASH Hook to access other features), **Message Waiting** Dial Tone (an off-hook interrupted Dial Tone indicating messages in voice mail), and **Confirmation** Dial Tone (an interrupted dial tone sequence indicating that a feature has been properly used, such as Cancel Call Waiting).

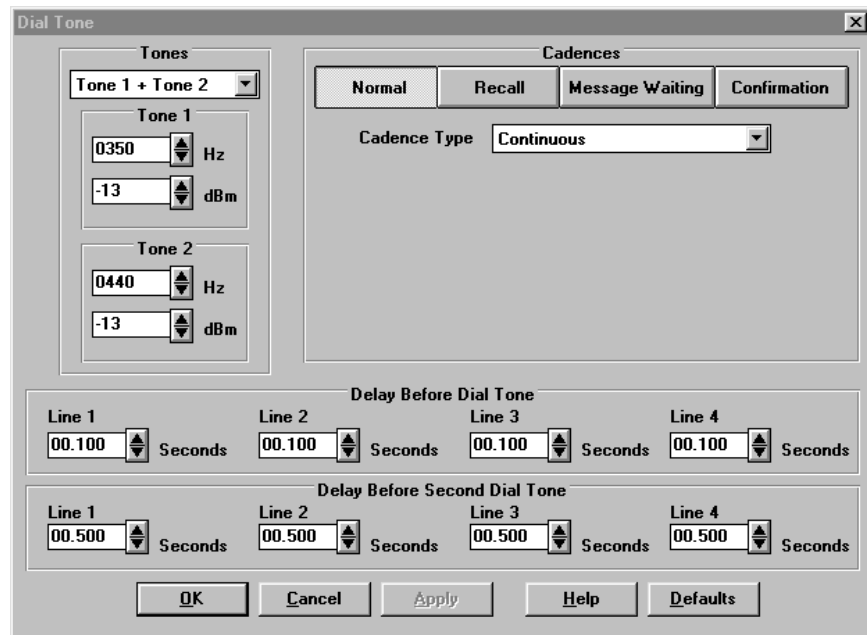

Figure 14. Dial Tone Screen

Dial Tone Level and Frequencies

Dial Tones may be single or dual frequencies with individually adjustable amplitudes. With a selection of Single Tone the system will only generate the first tone. With a selection of Tone 1 + Tone 2 the system will generate both tones with the specified frequencies and amplitudes. Purchase of the International Module adds the selection of Tone 1 x Tone 2. The system will generate Tone 1 modulation by Tone 2. In this implementation only the fundamental and upper side tone are generated, both at the amplitude programmed for Tone 1.

Frequency for both tones may be set from 10 Hz to 1000 Hz in 1 Hz increments and signal level from -06 dBm to -60 dBm in 1 dB increments.

Dial Tone Cadences

The TLE supports multiple dial tones. These include **Normal**, **Recall**, **Message Waiting**, and **Confirmation** dial tones. Each dial tone may be configured for continuous, simple or complex cadence.

Simple cadence has one on and one off time. Default is 0.1 seconds on, 0.1 seconds off. Complex cadence has two separate on/off times. Default is 0.1 seconds on, 0.1 seconds

off, 0.1 seconds on, 0.1 seconds off. The repeat number for both simple and complex cadences can be set from 1 to 20. If the **Repeat Forever** box is not checked (on the **Call Waiting** screen, continuous dial tone will follow the repeat sequence.

Delay Before Dial Tone

After going off-hook, this is the delay before dial tone is heard. It is programmable from 0 to 25 seconds. Default is 0.1 seconds.

Delay Before Second Dial Tone

Second Dial Tone is accessed by dialing the **Revert to Dial Tone** Phone Number (programmed on the Phone Number Screen). This is the delay before the Second Dial Tone is heard. It is programmable from 0 to 25 seconds. Default is 0.5 seconds.

Loop Parameters

Loop Parameters are those conditions that are directly related to the two wire loop: **Impedance**, **Attenuation**, and **Loop Current**. Impedance matching is important for many applications so that all signals sent to the switch network are absorbed and not reflected back to the caller. Attenuation is the loss in signal level (measured in dB) that occurs from one line to another. The TLE allows for programming of this loss on the receive side. Signals transmitted to the TLE are not attenuated until they reach the connected line. The TLE also allows for programming of the loop current, normally determined by the battery feed and the length of the loop.

	Impedance	Line Receive Attenuation	Loop Current
Line 1	900 ohms	04 dB	35 mA
Line 2	900 ohms	04 dB	35 mA
Line 3	900 ohms	04 dB	35 mA
Line 4	900 ohms	04 dB	35 mA

Figure 15. Loop Parameters Screen

Impedance

Impedance options for the TLE allow each line to be configured for either 600 (600 + 2.2 μ F) or 900 (900 + 2.2 μ F) ohms. The default is 900 ohms. Users who purchase the TLE-INTL software module (V2.00 or greater) will get three additional options for Line Impedance. These are the complex impedances for Australia, Germany, and the United Kingdom. Version 3.00 now includes Sweden.

Line Receive Attenuation

This value is the attenuation of the audio signal received at a port. **Line Receive Attenuation** may be set from 4 dB to 60 dB in 1 dB increments. These settings only affect signals received from other lines. They do not affect internally generated tones, e.g., Call Progress signals or Audio Playback.

Loop Current

Loop current is the amount of current that the TLE will supply to a device when it is off-hook. Each line is programmable and may be set from 10 mA to 70 mA in 1 mA increments $\pm 10\%$.

When loop current is set from 16 to 70 mA, the TLE will declare an off-hook at approximately 12 mA. When loop current is set from 10 to 15 mA, the TLE will declare an off-hook at approximately 8 mA.

Miscellaneous

Miscellaneous signals include **Disconnect Treatment**, **Confirmation Tones**, **Rotary Dial Only**, **Conference Type**, **Test Tones**, **Off-Hook Mode**, **Hunt Mode**, **Invalid Number Response**, and **Network Delay**.

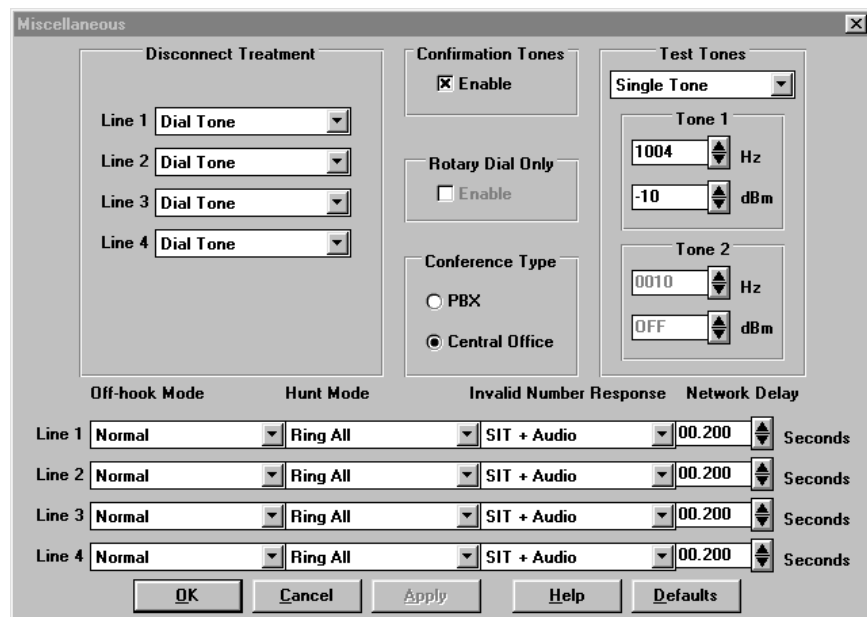

Figure 16. Miscellaneous Screen

Disconnect Treatment

Disconnect Treatment is the audible signal that is heard by a party when the other parties go on-hook. The options available include: **Dial Tone**, **Busy**, **Reorder**, **Silence**, and **Audio Message**.

Confirmation Tones

Confirmation Tones are tones that are issued during access to the Programming Mode, (accessed via ****99##** entry with a phone) when selecting a new Configuration, and

requesting version information from the TLE. After all valid and proper entries, a three beep sequence is issued. After an invalid entry, a longer single tone is issued.

Rotary Dial Only

Rotary Dial Only operation is to be used when there is a need to accept only Rotary Dialed (a.k.a. Pulse Dial) numbers. DTMF tones are still decoded during the first 30 seconds after power up for access to programming mode. (Only available with TLE-ADV and TLE-TEST modules.)

Conference Type

Conference Type allows for two different operations when a Conference Call is attempted. The differences in operation are detailed below (C.O. Conference is based upon Three Way Calling):

A typical Conference Call is initiated by generating a FLASH, Recall Dial Tone is heard, then a phone number is dialed to access the third (or fourth) party. If **PBX** Conference is selected, the originator of the conference must wait until the party answers before generating another Flash to bring all parties together.

- **PBX Conference**

Up to 4 lines may be connected in conference. The Called Party must answer before the second Flash to connect parties. Any party may hang up and all the others in the conference will remain connected

- **Central Office Conference**

Only three lines may be connected in a conference if a FLASH is generated before the Called Party answers, the remaining parties will hear ringing. If the Originating Party hangs up, all connections will be terminated

Test Tones

Test Tones is a user programmable single or dual tone that is accessed by dialing the Special Test Tone Phone Number. This phone number is set on the **Phone Number** screen. Default is 83785. With a selection of Single Tone the system will only generate the first tone. With a selection of Tone 1 + Tone 2 the system will generate both tones with the specified frequencies and amplitudes. Purchase of the International Module adds the selection of Tone 1 x Tone 2. The system will generate Tone 1 modulation by Tone 2. In this implementation only the fundamental and upper side tone are generated, both at the amplitude programmed for Tone 1.

Frequency range is 10 to 3000 Hz and output level is -0 dBm to -60 dBm.

If the **Test Tone** is set for dual tone output, the maximum level should be limited to -6 dBm per tone.

Off-hook Mode

Off-hook Mode is how the TLE handles a call when a device connected to the line meets the minimum Off-hook time. The options include: **Normal** (issues dial tone and waits for dialing), **Hotline** (will automatically ring the number programmed into the Revert to Dial Tone location), and **Silent** (will connect a device to a quiet Battery). Each line may be programmed individually.

Hunt Mode

Hunt Mode is how the TLE determines which line will ring when the same Phone Number is programmed for multiple lines. The options include **Ring All** (default), **Ring 1st Match**, **Ring 1st Available**, and **Ring Next**. Each Line may be programmed individually.

When the unit is set to **Ring All**, all lines with the same phone number will ring. When it is set for **Ring 1st Match**, the TLE will only ring the first line which has this number programmed. If that line is busy then a busy signal will be returned. When the **Hunt Mode** is set to **Ring 1st Available** it will start from line 1 and ring the first line that is idle, skipping over busy lines. When the **Hunt Mode** is set to **Ring Next Available**, it will ring the next higher line number after the last one used (e.g., if line 2 was the last line rung, line 3 will be rung).

For all **Hunt Modes**, all numbers in a Hunt Group must be programmed with the same number group. (i.e., 101, 102, 103, 104 together or 201, 202, 203, 204 together, etc.).

Invalid Number Response

Invalid Number Response is the signal that is sent to a caller when an invalid number is dialed, that is, one that does not match any of the programmed Phone Numbers in the TLE. The options include **SIT** (Special Information Tones), **Reorder**, **Ringback**, **Silence**, and **Audio** (a stored audio message). Each line may be programmed individually. When SIT is selected the unit will output SIT, followed by the Audio message.

Network Delay

Network Delay is a timer that is used after a dialed sequence is complete before the TLE issues any network responses, such as Ringback, Busy, Reorder, or Audio. Each line may be programmed individually from 0 to 25 seconds in 5 mS increments.

Phone Numbers

Phone Numbers are used to access each Line, Revert to Dial Tone (a.k.a. 2nd Dial Tone), and Test Tones (Dial Tone, Busy, Reorder, Ringback, Special Test Tone, and Stuttered Dial Tone). Each Phone Number is programmable from 0 to 16 digits in length.

Note: Care should be taken that **NO** Phone Number starts as a subset of another, except for the **Revert to Dial Tone Number**. For example, line 1's default phone number is 101. You cannot program another phone number to be 1015.

	Group 1 Number	Group 2 Number	Group 3 Number	Revert To Dial Tone / Hot Line Number
Line 1	101	201	301	9
Line 2	102	202	302	9
Line 3	103	203	303	9
Line 4	104	204	304	9

Dial Access Message	411
Dial Tone	83781
Busy	83782
Reorder	83783
Ringback	83784
Special Test Tone	83785
Stuttered Dial Tone	83786

Figure 17. Phone Numbers Screen

Revert to Dial Tone

The Revert to Dial Tone number is programmable from 0 to 16 digits in length. When this number is dialed a second dial tone is heard. Default is 9.

Dial Tone - Test Number

This is the telephone number dialed to access a continuous **Normal** Dial Tone as programmed in the **Dial Tone** screen. The telephone number is programmable from 0 to 16 digits in length and the default setting is 83781.

Busy - Test Number

This is the telephone number dialed to access a continuous **Busy** signal programmed in the **Busy** screen. The telephone number is programmable from 0 to 16 digits in length and the default setting is 83782.

Reorder - Test Number

This is the telephone number dialed to access a continuous **Reorder** tone programmed in the **Reorder** screen. The telephone number is programmable from 0 to 16 digits in length and the default setting is 83783.

Ringback - Test Number

This is the telephone number dialed to access a continuous **Ringback** tone programmed in the **Ringback** screen. The telephone number is programmable from 0 to 16 digits in length and the default setting is 83784. In the TLE, ringback is always synchronized with the ring signal at the called line.

Special Test Tone - Test Number

This is the telephone number dialed to access the **Special Test Tone** programmed in the **Miscellaneous** screen under **Test Tones**. It is programmable from 0 to 16 digits in length and the default setting is 83785. The default test tone is 1004 Hz at -10 dBm.

Stuttered Dial Tone - Test Number

This is the telephone number dialed to access the **Stuttered Dial Tone** programmed in the **Dial Tone** screen under **Confirmation**. It is programmable from 0 to 16 digits in length and the default setting is 83786.

Port Configuration

By default the TLE operates as a 4 line unit with a single Active Configuration. Under this scenario there are certain global parameters which apply to all lines, for example, Call Progress frequencies, such as Dial Tone or SIT.

Independent switch operation, ports 2 & 4 is a special mode to allow for more versatile programming of the TLE. When this mode is selected, the unit will operate with one configuration for ports 1 and 3 and a second configuration for ports 2 and 4. To edit a port's parameters, the appropriate configuration must first be selected as the Edit Configuration. However, for certain global parameters, such as date/time for Caller ID, the TLE can only accept one value. In these cases, the unit will always use the values from the first configuration – the edit function is disabled for these parameters in the second configuration.

Port Configuration allows the user to change the Edit Configuration from **4 Port** (normal) operation to **2x2 Port** (dual two-port) operation with Lines 1 and 2 acting as a separate platform that is isolated from Lines 3 and 4. The **Clone** operation can be used to make the two-port platforms identical by copying the non-global parameters from Lines 1 and 2 over to Lines 3 and 4.

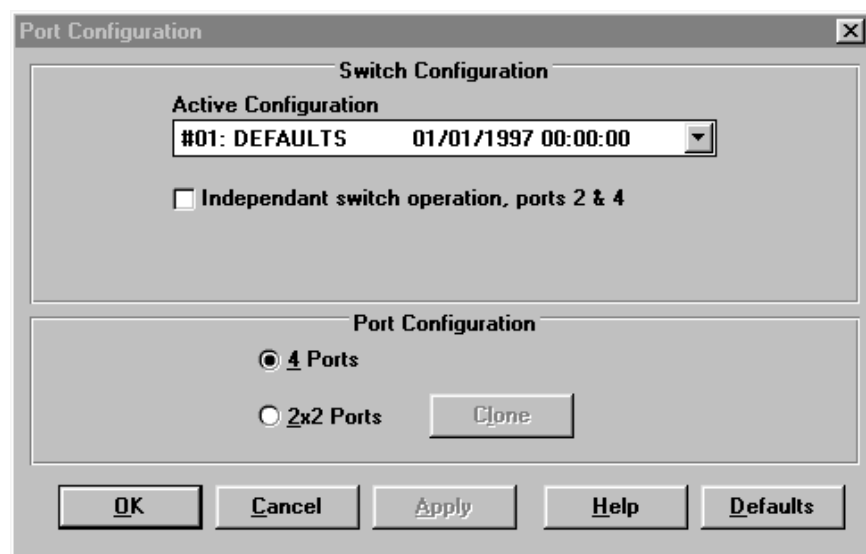

Figure 18. Port Configuration Screen

Clone

Clone is used when configuring the TLE for 2x2 operation. Enabling this feature will clone (or copy) an exact duplicate of the settings for Lines 1 & 2 to Lines 3 & 4 so that the Edit Configuration is split into two identical setups. After the **2x2 Ports** is selected, and the screen is closed (**OK**) the **Clone** feature is disabled. To enable the Clone feature again, select **4 Ports**, then **2x2 Ports**. A dialog box will appear. To Clone lines 1 & 2 to Lines 3 & 4, select **Yes**.

Reorder

The Reorder signal is an indication that trunk circuits are not available. Reorder Tone has several variables, including: **Single Tone** or **Dual Tone**, **Output Level**, and a **Simple** or **Complex Cadence**.

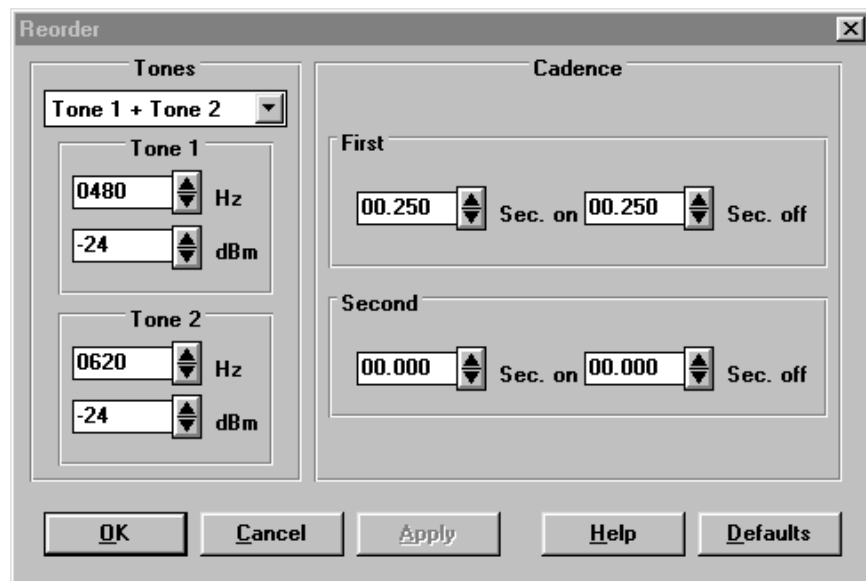

Figure 19. Reorder Screen

Reorder

Reorder tones may be single or dual frequencies with individually adjustable amplitudes. With a selection of Single Tone the system will only generate the first tone. With a selection of Tone 1 + Tone 2 the system will generate both tones with the specified frequencies and amplitudes. Purchase of the TLE-INTL Software Module adds the selection of Tone 1 x Tone 2. The system will generate Tone 1 modulation by Tone 2. In this implementation only the fundamental and upper side tone are generated, both at the amplitude programmed for Tone 1.

Frequency range for both tones may be set from 10 Hz to 1000 Hz in 1 Hz increments.

Output level may be set from -6 dBm to -60 dBm per tone in 1 dB increments.

Reorder Cadence

First Cadence on time may be set from 100 mS to 1000 mS in 5 mS increments.

First Cadence off time may be set from 100 mS to 1000 mS in 5 mS increments.

Second Cadence on time may be set from 100 mS to 1000 mS in 5 mS increments.

Second Cadence off time may be set from 100 mS to 1000 mS in 5 mS increments.

If the **Second Cadence** values are programmed to zero the unit will repeat the sequence with the first cadence values.

Ringling

Ringling is the AC voltage that is applied to a Line to alert a device to an incoming call. A minimum ring signal (according to Bellcore) is 40 VAC RMS at 1 REN. The variable parameters available in the TLE include **Ring Frequency**, **Voltage Level**, and **Cadence**. Ring Cadence is programmable for each of the three groups of Telephone Numbers in 1, 2, or 3 On/Off sequences (a.k.a. Ring Cycle, Ringing Period). Telephone numbers 1, 2, and 3 are set on the **Phone Numbers** screen.

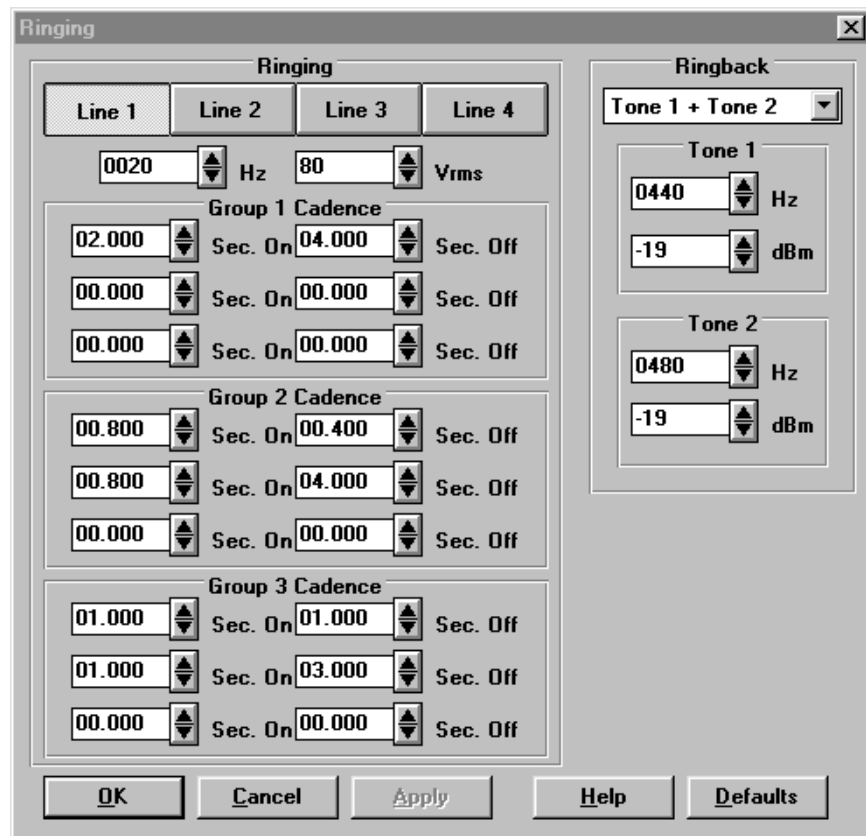

Figure 20. Ringling Screen

Ringling - Lines 1, 2, 3, 4

Ring frequency may be set from 17 Hz to 70 Hz in 1 Hz increments. Ring voltage may be set from 20 Volts AC RMS to 80 Volts AC RMS in 5 Volt increments.

The actual ring voltage seen at T/R will depend on (REN) ringer equivalence of the load.

Cadence - Group 1, 2, 3

Cadence may be set for 1, 2 or 3 sequences from 0 to 3 seconds on and 0 to 10 seconds off in 5 mS increments.

Ringback

Ringback is the audible tone heard by a caller while ringing is applied to the called line. The TLE Ringback tone will match the Ring cadence of the Line called and is programmable as a single or dual frequency with programmable levels and is applied to all lines. With a selection of Single Tone the system will only generate the first tone. With a selection of Tone 1 + Tone 2 the system will generate both tones with the specified frequencies and amplitudes. Purchase of the TLE-INTL Software Module adds the selection of Tone 1 x Tone 2. The system will generate Tone 1 modulation by Tone 2. In this implementation only the fundamental and upper side tone are generated, both at the amplitude programmed for Tone 1.

Frequency range for Tone 1 and Tone 2 may be set from 10 Hz to 1000 Hz in 1 Hz increments.

Output Level may be set from -6 dBm to -60 dBm per tone in 1 dB increments.

Special Information Tones/Number Unobtainable Tone

SIT (Special Information Tones) consists of three tones that are generated by the network when an abnormal condition exists. These have evolved over time to be primarily used before audio announcements that indicate "All circuits are busy, please try your call again later", "The number you have dialed is no longer in service", and other audio announcements. The TLE allows the programming of the **Frequency, Signal Level, and On/Off Durations** for these tones.

Countries other than US/Canada may use a Number Unobtainable Tone response. This feature is available when the TLE International Module is purchased.

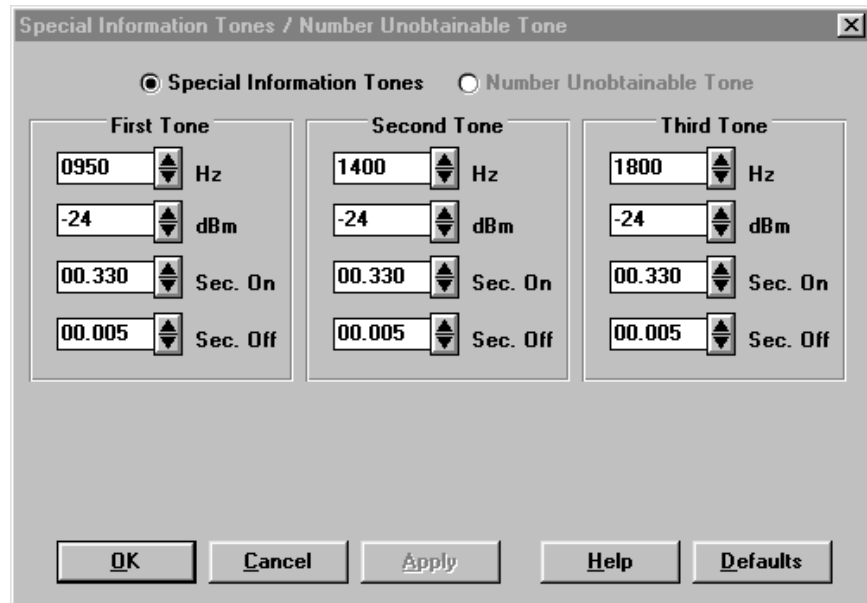

Figure 21. Special Information Tones/Number Unobtainable Tone Screen

Frequency range for all three tones may be set from 10 Hz to 2000 Hz in 1 Hz increments. Signal level may be set from -6 dBm to -60 dBm in 1 dBm increments. On duration may be set from 0 to 10.000 seconds in 5 mS increments. Off duration may be set from 0 to 10.000 seconds in 5 mS increments.

Note: For Number Unobtainable Tone Information, go to TLE-INTL Software Module section.

Voice Messages

Voice Messages are audible signals that are stored internally in the TLE in a 8.000 kHz 8-bit μ -law WAV file format. These are capable of being imported via the serial port. Initial support is for 4 messages with a maximum total length of 8 seconds broken into 0.5 second blocks. Message names include **Invalid Number**, **Disconnect**, **Dial Access**, and **Alternate**.

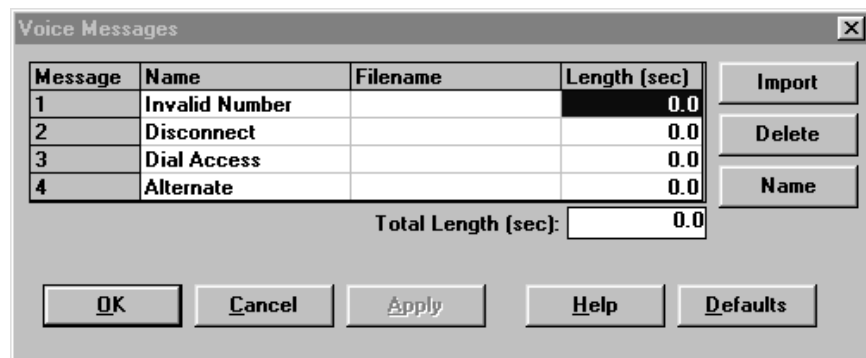

Figure 22. Voice Messages Screen

Invalid Number

The default message for **Invalid Number** is:

“The number you have dialed is incorrect. Please hang up and dial again.”

This message will be played when any invalid phone number is dialed.

Disconnect

The default message for **Disconnect** is:

“Please hang up.”

Dial Access

The default for **Dial Access** is:

“Today’s message is: Buy Teltone products.”

Alternate

The **Alternate** message is programmable with no default set.

References

Teltono has used the following references in the development of the TLE-BASE and the TLE-ADV software:

- [1] TR-TSY-00064 LSSGR Issue 2, Section 6, (Signaling)
- [2] TR-NPL-000275 BOC Notes on the LEC Networks (BNLN), Issue 2, April 1994
- [3] GR-30-CORE, Bellcore Publication, LSSGR: Voiceband Data Transmission Interface, Section 6.6, Issue 1, 12/94
- [4] TR-NWT-000030, Bellcore Publication, Voiceband Data Transmission Interface Generic Requirements, Issue 2, 10/92
- [5] TR-NWT-000031, Bellcore Publication, CLASS Feature: Calling Number Delivery (CND), Issue 4, 12/92
- [6] TR-NWT-001188, Bellcore Publication, CLASS Calling Name Delivery Generic Requirements (CNAM), Issue 1, 12/91
- [7] TR-NWT-001401, Bellcore Publication, Visual Message Waiting Indicator Generic Requirements FSD 01-02-2000, Issue 1, 9/93
- [8] SR-INS-002461, Bellcore Publication, Customer Premise Equipment Compatibility Considerations for the Analog Display Services Interface, Issue 1, 12/92
- [9] TR-NWT-001273, Bellcore Publication, Generic Requirements for an SPCS CPE Data Interface for Analog Display Services, Issue 1, 12/92
- [10] SR-NWT-002495, Bellcore Publication, Guidelines for Writing Applications Which Use the Analog Display Services Interface (ADSI) for Data Communications, Issue 1, 12/92
- [11] GR-416-CORE, Bellcore Publication, CLASS Feature: Call Waiting Deluxe, Issue 1, 4/95

Advanced Emulation Software Module (TLE-ADV)

The TLE Advanced Emulation Module provides 16 different configuration settings, the ability to enable Caller ID after every ring and the ability to disable DTMF detection. In addition, this module provides emulation of impairments, metering tones, and the ability to measure signal level. This module is sold separately. See the Ordering Information section of this manual for details.

Note: This upgrade requires a software key that is generated by Teltone when the user supplies the TLE Unit ID and the TLE-ADV serial number to Teltone. The instructions are included on the Application Guide with the upgrade module.

Rotary Dial Only

Rotary Dial Only operation is to be used when there is a need to accept only rotary dialed (a.k.a. pulse dial) numbers. DTMF tones are still decoded during the first 30 seconds after power up. This feature is programmed on the **Miscellaneous** screen.

Caller ID After Every Ring

Caller ID After Every Ring is a feature that will send the FSK sequence after every Power Ring Cycle. This feature is programmed on the **Caller ID** screen (TLE-ADV and TLE-ICID modules only.)

Impairments

Echo

Echo is a reflection of the signal from a connected device back to that equipment. The **Echo Delay** can be set from 0 to 100 mS in 125 μ S (default is 0). The **Attenuation**, relative to the strength of the original signal, can be set from 4 dB to 60 dB (default is 60 dB). Level accuracy will be maintained within ± 1 dB of setting.

White Noise

The **White Noise** operation provides a uniformly distributed noise source which is band limited, starting at approximately 3.4 kHz. **White Noise** can be enabled for each line. Default is disabled. If enabled, the **White Noise** volume can be set from 20 dBrn to 85 dBrn (default is 20 dBrn).

Noise source is broadbanded over 300 to 3400 Hz range (no C message weight). Level accuracy is ± 2 dB for values from 20 to 85 dBrn.

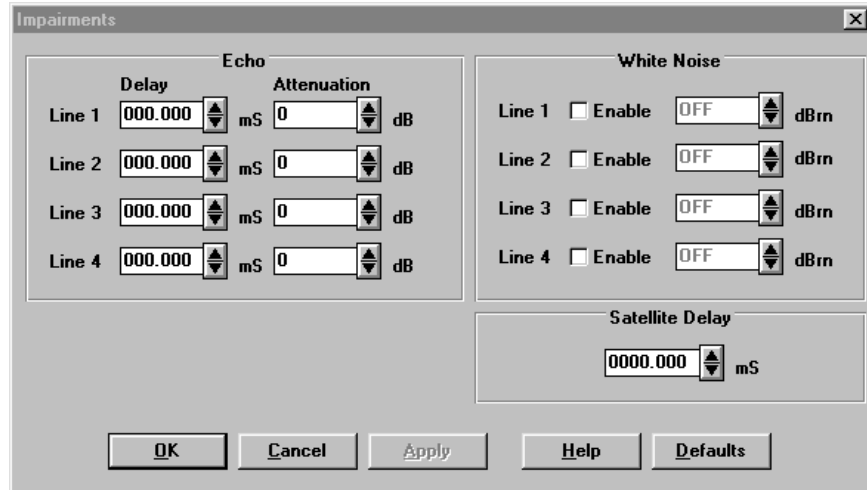

Figure 23. Impairments Screen

Satellite Delay

Satellite Delay emulates the time it would take a signal to travel from one satellite earth station to the satellite then back to another satellite earth station. **Satellite Delay** can be set from 0 to 1000 mS in 125 μ S increments (default is 0).

Satellite Delay must be set for all lines with the same delay. This implementation will also provide a far end echo due to mismatch of the line and device impedance at the far end. This effect may be minimized by increasing the line attenuation for both lines in the connection.

Metering Tones

Metering Tones are primarily used in international applications. These tones are provided to customers when they place a phone call indicating what rate they will be billed for the call. Each line can be programmed to enable or disable **Metering Tones**.

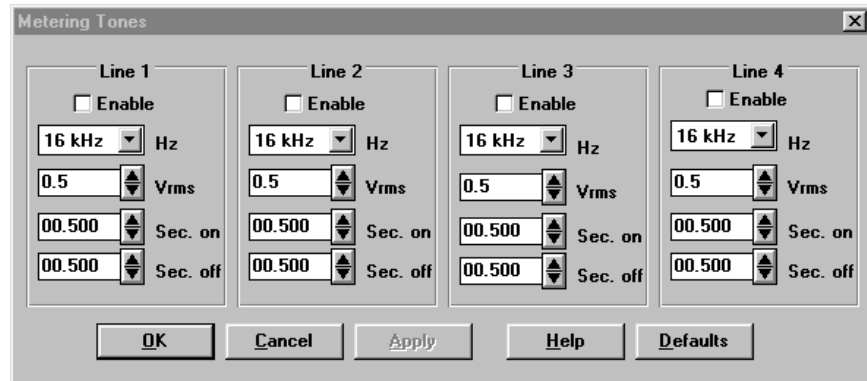

Figure 24. Metering Tones Screen

The frequency of the tone can be set at 16 kHz or 12 kHz.

The voltage of the tone can be set from 0 to 5 Vrms in 100 mV increments (default is 3 Vrms).

The tone cadence can be set from 0 to 10 seconds on, and 0 to 10 seconds off in 5 mS increments (default is 0.5 seconds on, 0.5 seconds off).

If both lines have them enabled, **Metering Tones** are sent to both parties in the connection.

Signal Level Measurement

This screen displays the amplitude of a signal in either dBm or mV. The TLE must be connected to the PC to measure and display the signal level.

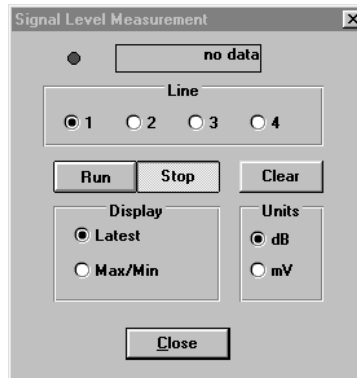

Figure 25. Signal Level Measurement Screen

Note: This screen is visible only if TLE-ADV is installed and the TLE hardware is connected.

The LED at the top of the screen will blink between red and green once per second indicating the PC is receiving data from the TLE. The signal level can be displayed as a time-averaged RMS reading, or the maximum/minimum during the sample period. The measurement will continue until the **Stop** button is pressed or the screen is closed. The value displayed will correspond to the signal within the telco audio band (roll off at approximately 3.4 kHz).

International Software Module (TLE-INTL)

The TLE International Software Module includes 11 preset country configurations and 5 settings preset to North America. An additional 11 countries are also included with the software and are installed when the 'Sample Configuration Files' option is selected during the software installation process. The TLE-INTL Software Module is an upgrade to the TLE Base unit which provides certain default country specific operational characteristics. These include: line impedance, ringing cadence, ringing voltage, ringing frequency, call progress levels, call progress frequencies, call progress cadences and line reversal.

The default countries supported (one per configuration) are: Australia, Brazil, France, Germany, Ireland, Japan, Korea, Netherlands, Singapore, Sweden, United Kingdom, and US/Canada. The remaining 4 configurations are configured for US/Canada. The additional country configurations available are Austria, Belgium, China, Denmark, Finland, Greece, India, Italy, Norway, Spain and Switzerland. This module is compatible with all features of the base unit, and may be co-resident with the TLE-ADV Software Module. When this module is resident, the TLE will store the programming of up to 16 configurations, versus only two configurations in the base unit.

Note: The TLE-INTL Software Module will allow Caller ID to be enabled for other countries, but it conforms to the Bellcore (USA/Canada) standards to support other Caller ID standards. The TLE-ICID Software Module is available as an upgrade to the TLE-INTL.

Rotary Dialing

The TLE rotary dial algorithm will allow the detection of the two most common rotary dial specifications:

1. 40 mS/60 mS make/break ratio (U.S., Germany, Sweden, etc.)
2. 33 mS/67 mS make/break ratio (U.K., France, Ireland, etc.)

The digit translation will follow the U.S. standard (digit 1 = 1 pulse, digit 2 = 2 pulses, etc.) for all countries.

Note: This upgrade requires a software key that is generated by Teltone when the user supplies the TLE Unit ID and the TLE-INTL serial number to Teltone. The instructions are included on the Application Guide with the upgrade module.

References



Teltone has used the following references for each of the countries specified, however, you may find that certain parameters may be different for any specific country. It is up to the user to verify that operating parameters are valid for their application and usage.

- [1] TR-TSY-000064 LSSGR Issue 2, Section 6, (Signaling)
- [2] TR-NPL-000275 BOC Notes on the LEC Networks (BNLN), Issue 2, April 1994

Telephone Line Emulator User's Manual

- [3] GR-30-CORE, Bellcore Publication, LSSGR: Voiceband Data Transmission Interface, Section 6.6, Issue 1, 12/94
- [4] ITU Fascicle II.2, Recommendation E.180, Supplement #2, 1/94, Telephone Network and ISDN - Operation, Numbering, Routing, and Mobile Services - Various Tones Used in National Networks
- [5] ETSI, European Telecommunications Standard, (ETS300-001), Attachments to the Public Switched Telephone Network; General technical requirements for equipment connected to an analogue interface in the PSTN (Candidate NET 4), March 1992.
- [6] British Standard BS 6305: 1992, General requirements for apparatus for connection to the public switched telephone network run by certain public telecommunications operators.
- [7] Swedish Specification TVT 8211-A 112E, Technical requirements for connection of subscriber equipment to the public switched telephone network.
- [8] Singapore TAS TS PSTN 1, Issue 3 Rev 4, 1 April 1997, Approval Specification for terminal equipment for connection to Public Switched Telephone Network & Analogue Leased Circuits.
- [9] Japan Approvals Institute for Telecommunications Equipment web site: (accessed 9/29/97) <http://www.sphere.ad.jp/jate/english>. Overview of Technical Conditions, Conditions specific to Analog Telephone Terminals. Ordinance Concerning Terminal Facilities, Terminal Facilities to be Connected to Telephone Circuit Facilities.

Reset to Defaults

Note: When the front panel Reset button is pressed, the unit will be reset to the US/Canada defaults for all 16 configurations (country codes). The user must perform "Defaults" and "Send All" from the PC configuration software to reload the defaults for each individual country.

Country Screen



Figure 26. Country Screen

This screen copies the default values of the selected country into the current **Edit Configuration**. For example, from the **Main** screen, under **Edit Configuration**, select configuration "#16 DEFAULTS". Then using the **General Setup** button or the **Screens** pull down menu, select **Country**. Choose one of the stored countries default values to copy into the current **Edit Configuration**, such as United Kingdom. After **OK** or **Apply** is

selected, a screen will appear requesting confirmation of your selection. Selecting **OK** will copy the default values for the selected country into the current **Edit Configuration**. If additional changes are made - it is recommended that the **Name** be changed, using the **Main** screen **Name** button, to an appropriate name.

Importing Additional Countries

The TLE maintains a maximum of 16 independent configurations. When you import a country configuration file, the imported configuration replaces one of the existing 16 configurations.

To import additional country configurations, follow the steps below:

1. In the Edit Configuration area of the main TLE screen, select one of the 16 configurations. The configuration that you select will be replaced by the imported additional country settings. To maximize the capabilities of the TLE, select a default configurations (for example, #13 DEFAULTS).

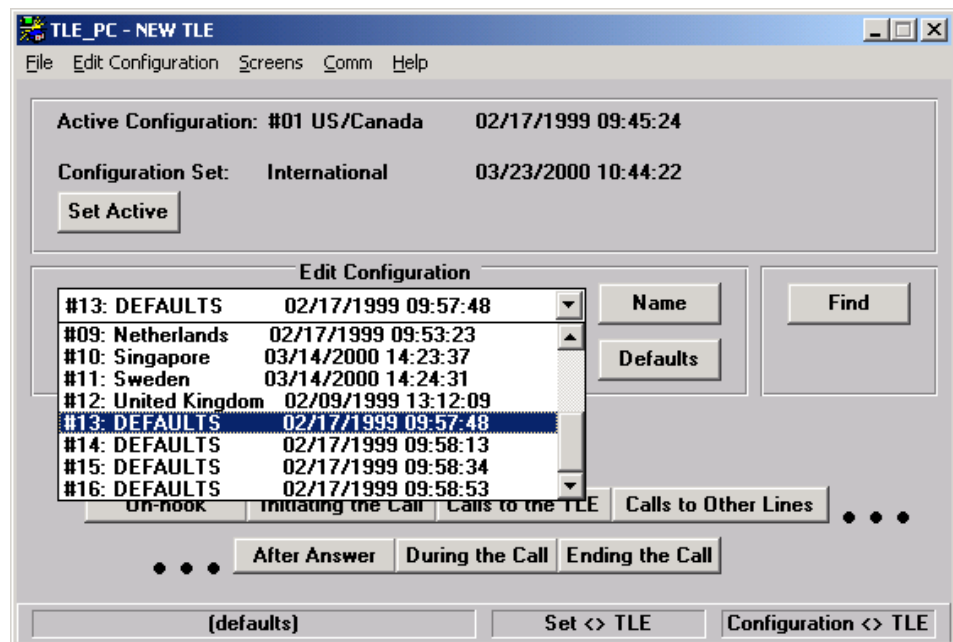

Figure 27. Selecting a Configuration to be Replaced by the Additional Country

2. Select the Import Single Configuration command on the File menu.
3. In the Import Single Configuration dialog box, select the country configuration file you want to import (for example, Austria.tlc).

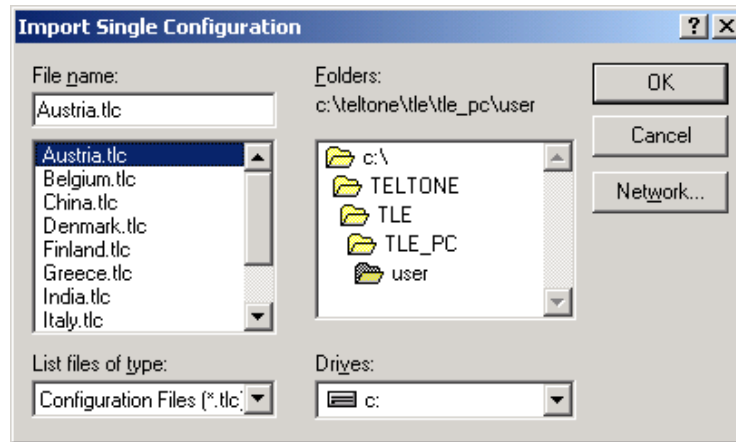

Figure 28. Importing a Single Configuration

4. Click the OK button.
5. With the imported country configuration displayed in the Edit Configuration area of the main TLE screen, click the Send button to download the configuration to the TLE.

Once a configuration is sent to the TLE, that configuration is stored in nonvolatile memory and is retained until the TLE is told to load a different configuration. To use a configuration, select it as the active configuration.



Because the imported files do not have unique default parameters, they reset to another country's parameters if the Defaults button is clicked. If the Defaults button is clicked accidentally, click Query if you are in the main screen or Cancel on any other screen; otherwise, you may send inappropriate parameters to the TLE. You can only recover by importing the configuration again or by manually correcting the altered parameters.

Call Waiting

The Caller ID / release of TLE-PC software Version 3.00 supports Caller ID formats other than Bellcore (USA/Canada) with an upgrade. The TLE-ICID, International Caller ID module, is an upgrade to the TLE-INTL, International Signaling module. This module supports variations based upon Bellcore, ETSI FSK, and ETSI DTMF Caller ID standards. One variation is called Bellcore Plus, an expanded version based upon Bellcore that is used in Australia and Singapore. This upgrade combines the Caller ID and Call Waiting Screens from previous versions to allow many parameters to be programmed so that the TLE will support almost all Caller ID variations around the world. Default configurations are provided for the following countries; Australia, France, Germany, Netherlands, Singapore, Sweden, United Kingdom, and USA/Canada. Other country configurations may be available for download and import from the Teltone Web site at <http://www.teltone.com>. Requests for other country configurations should be directed to info@teltone.com.

Metering Tones

The BS6305 document (UK) states that "Meter pulses are normally provided only by special arrangement between the PTT and the user, but may be present whether or not the supply of them has been requested."

The other documents (ITU, Swedish TVT 8211-A 112E, Singapore TAS TS PSTN 1, etc.) make no mention about the circumstances under which meter pulses are provided. Therefore meter pulses will be off, by default, for all countries.

Metering Tones are primarily used in international applications. These tones are provided to customers when they place a phone call indicating what rate they will be billed for the call. Each line can be programmed to enable or disable Metering Tones.

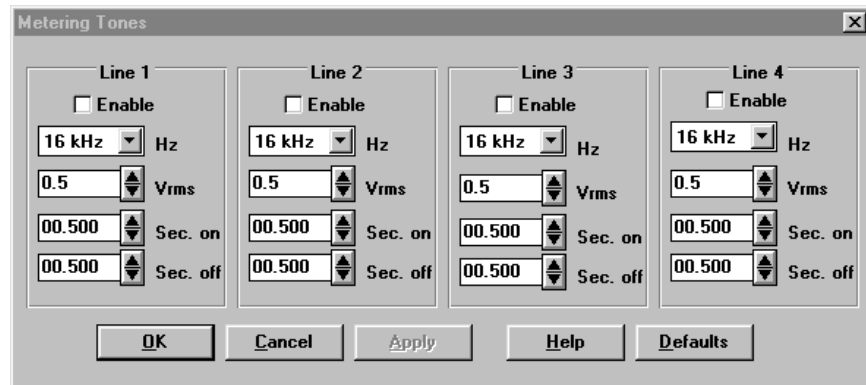

Figure 29. Metering Tones Screen (TLE-INTL)

The frequency of the tone can be set at 16 kHz or 12 kHz.

The voltage of the tone can be set from 0 to 5 Vrms in 100 mV increments (default is 3 Vrms).

The tone cadence can be set from 0 to 10 seconds on, and 0 to 10 seconds off in 5 mS increments (default is 0.5 seconds on, 0.5 seconds off).

If both lines have them enabled, **Metering Tones** are sent to both parties in the connection.

Special Information Tones/Number Unobtainable Tone

When a subscriber dials an invalid number, the method used to alert the subscriber varies from country to country. Some countries return a Number Unobtainable Tone, some return Special Information Tones, some return a recorded announcement, and some return SIT tones followed by a recorded announcement. The use of SIT tones seems to be evolving as an international standard, with some countries currently using Number Unobtainable Tone, but planning to use SIT in the future. In the TLE, under the **Special Information Tone/Number Unobtainable Screen**, the user must select either **Special Information Tone** or **Number Unobtainable** for all lines. Then in the **Miscellaneous** screen under **Invalid Number Response** they may select a particular response, on a per line basis.

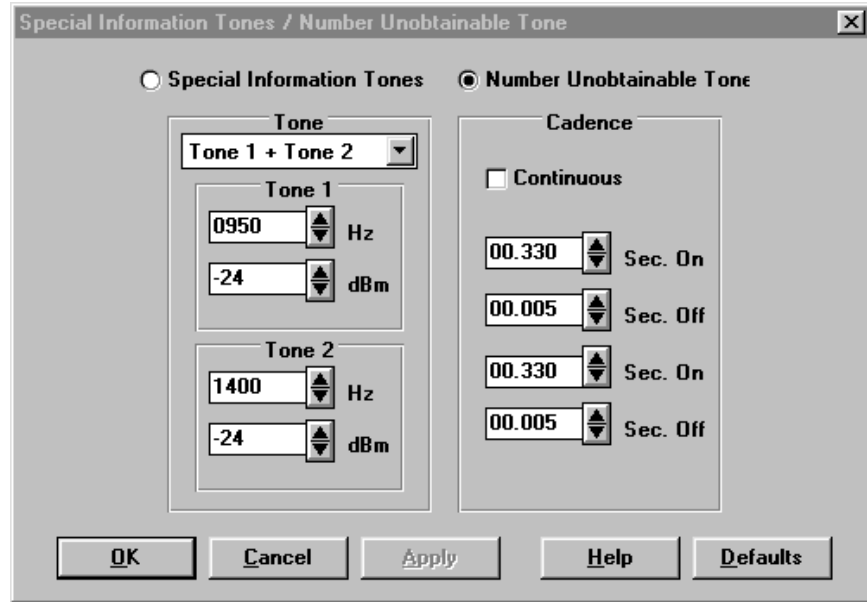

Figure 30. Special Information Tones/Number Unobtainable Tone Screen

These tones are programmable as a single or dual frequency with programmable levels and is applied to all lines. With a selection of Single Tone the system will only generate the first tone. With a selection of Tone 1 + Tone 2 the system will generate both tones with the specified frequencies and amplitudes. Purchase of the TLE-INTL Software Module adds the selection of Tone 1 x Tone 2. The system will generate Tone 1 modulation by Tone 2. In this implementation only the fundamental and upper side tone are generated, both at the amplitude programmed for Tone 1.

Frequency range may be set from 10 Hz to 2000 Hz in 1 Hz increments.

Signal level may be set from -6 dBm to -60 dBm in 1 dB increments.

On duration may be set from 0 Seconds to 10.000 Seconds in 5 mS increments.

Off duration may be set from 0 Seconds to 10.000 Seconds in 5 mS increments.

Loop Parameters (TLE-INTL)

Complex Impedance

The TLE Loop Parameters were upgraded in the TLE-INTL module in TLE_PC software release Version 2.00. This upgrade, to the TLE Loop Parameters, has added complex impedance's for Australia, Germany, and the United Kingdom. These parameters are loaded into the programmable SLIC used in the TLE. The details include:

- Australia: $220\Omega + (820\Omega \parallel 120\text{nF})$
- Germany: $220\Omega + (820\Omega \parallel 115\text{nF})$
(This complex impedance is also used in Switzerland.)
- Sweden: $270\Omega + (750\Omega \parallel 150\text{nF})$ (Version 3.00 or greater)
(This complex impedance is also used in Ireland.)
- United Kingdom: $370\Omega + (620\Omega \parallel 310\text{nF})$

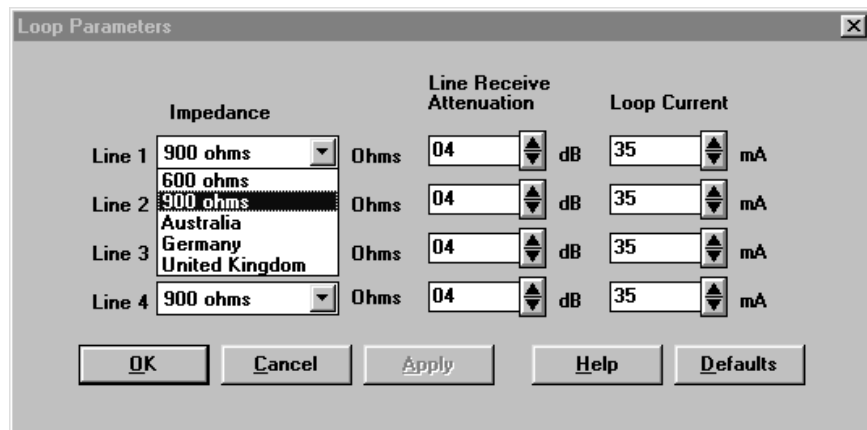

Figure 31. Loop Parameters (TLE-INTL)

Country Default Settings

The following pages list all the available country default settings.

Telephone Line Emulator User's Manual

Australia Defaults

The settings for this country will be stored in configuration #2.

Dial Tone:	
Frequency:	425 Hz x 25 Hz (425 HZ modulated by 25 Hz)
Level:	-10 dBm
Cadence:	Continuous
Busy Tone:	
Frequency:	400 Hz
Level:	-10 dBm
Cadence:	375 mS on/375 mS off
Reorder Tone:	
Frequency:	400 Hz
Level:	-10 dBm
Cadence:	375 mS on/375 mS off, alternate level reduced by 10 dB
Ringing Tone:	
Frequency:	400 Hz
Level:	-10 dBm
Cadence:	.4 S on/.2 S off/.4 S on/ 2 S off
Ringing:	
Frequency:	25 Hz
Amplitude:	70 VRMS
Cadence:	.4 S on/.2 S off/.4 S on/ 2 S off
SIT or Number Unobtainable:	
Frequency:	400 Hz
Level:	-10 dBm
Cadence:	2.5 S on/.5 S off
Comments:	Australia uses Number Unobtainable tone or recorded announcement will use announcement as default
Call Waiting Tone:	
Frequency:	425 Hz
Level:	-10 dBm
Cadence:	.1 S on/.1 S off/.1 S on every 4.7 sec
Line Impedance:	Australia 220 Ω +(820 Ω 120nF)
Line Reversal:	Disabled

Austria Defaults

To make the settings for this country available, follow the instructions in "Importing Additional Countries" on page 41.

Description	Frequency (Hz)	Cadence*1	Signal level
Dial Tone	420 // 450	Continuous	-26dBm to -16dBm
Recall Dial Tone	420	Continuous	-26dBm to -16dBm
Special Dial Tone	380 + 420	Continuous	-26dBm to -16dBm
Ringing Tone	420 // 450	1.0(on)-5.0(off)	-43dBm to -6.5dBm
Ringing Signal	50	1.0(on)-5.0(off)	26Vac to 66Vac
Busy Tone I	420 // 450	0.4(on)-0.4(off)	-43dBm to -6.5dBm
Busy Tone II	420 // 450	0.3(on)-0.3(off)	-43dBm to -6.5dBm
Congestion Tone	420 // 450	0.2(on)-0.2(off)	-43dBm to -16dBm
SIT Tones	950	0.33(on)	-43dBm to -9dBm
	1400	0.33(on)	-43dBm to -9dBm
	1800	0.33(on)-1.0(off)	-43dBm to -9dBm
Call Waiting Tone	420	0.04(on)-1.95(off)	-36dBm to -10dBm
Metering Tones	12 000	0.05(on)-0.05(off)	50mV to 2.5V

Impedance: 600 Ω

fff//fff is defined because some exchanges use the first frequency and is the default, and other exchanges use the second frequency.

Belgium Defaults

To make the settings for this country available, follow the instructions in "Importing Additional Countries" on page 41.

Description	Frequency (Hz)	Cadence *1	Signal level
Dial Tone	425 // 450	Continuous	-20dBm to -4dBm
Special Confirmation	425 // 450	0.04(on)-0.04(off)	-20dBm to -4dBm
Special Dial Tone	425 // 450	1.0(on)-0.25(off)	-20dBm to -4dBm
International Dial Tone	900	0.33(on)	-28dBm to -4dBm
	1020	0.33(on)	-28dBm to -4dBm
	1140	0.33(on)	-28dBm to -4dBm
Ring Tone	425 // 450	1.0(on)-3.0(off)	-37dBm to -4dBm
Ring Signal	25Hz	1.0(on)-3.0(off)	75Vac to 90Vac
Busy Tone	425 // 450	0.5(on)-0.5(off)	-37dBm to -4dBm
Congestion Tone	425 // 450	0.167(on)-0.167(off)	-37dBm to -4dBm
SIT Tones	900	0.33(on)	-42dBm to -4dBm
	1380	0.33(on)	-42dBm to -4dBm
	1860	0.33(on)-1.0(off)	-42dBm to -4dBm
	or		
	950	0.33(on)	-42dBm to -4dBm
	1400	0.33(on)	-42dBm to -4dBm
Metering Tones	1800	0.33(on)-1.0(off)	-42dBm to -4dBm
	16 000	0.08(on)-0.22(off)	-18dBm to +17 dBm

Impedance: 600 Ω or 150 Ω + (830 Ω in parallel with 72nF) for digital PBXs with analogue interface

fff//fff is defined because some exchanges use the first frequency and is the default, and other exchanges use the second frequency.

Brazil Defaults

The settings for this country will be stored in configuration #3.

Dial Tone:
 Frequency: 425 Hz
 Level: -10 dBm
 Cadence: Continuous

Busy Tone:
 Frequency: 425 Hz
 Level: -10 dBm
 Cadence: .25 S on/.25 S off

Reorder Tone:
 Frequency:
 Level:
 Cadence:
 Comment: Not used, will use Busy

Ringing Tone:
 Frequency: 425 Hz
 Level: -10 dBm
 Cadence: 1 S on/ 4 S off

Ringing:
 Frequency: 25 Hz
 Amplitude: 80 VRMS
 Cadence: 1 S on/4 S off
 Comments: Values based on Portugal standard (per ETSI)

SIT or Number Unobtainable:
 Frequency: 425 Hz
 Level: -10 dBm
 Cadence: .75 S on/.25 off/.25 on/.25 off

Call Waiting Tone:
 Frequency: 425 Hz
 Level: -10 dBm
 Cadence: .05 S on/1 S off

Line Impedance: 600 Ω
 Comments: Values based on Portugal standard (per ETSI)
 Line Reversal: Disabled

China Defaults

To make the settings for this country available, follow the instructions in "Importing Additional Countries" on page 41.

Description	Frequency (Hz)	Cadence *1
Dial Tone	450	Continuous
Second Dial Tone	450	Continuous
Ringing Tone	450	1.0(on)-4.0(off)
Busy Tone	450	0.35(on)-0.35(off)
Congestion Tone	450	0.7(on)-0.7(off)
SIT Tone I	450	0.4(on)-0.04(off)
SIT Tone II	950	0.4(on)-10.0(off)
Number Unobtainable	450	3x[0.1(on)-0.1(off)]-0.4(on)-0.4(off)
Call Waiting Tone	450	0.4(on)-4.0(off)

Denmark Defaults

To make the settings for this country available, follow the instructions in "Importing Additional Countries" on page 41.

Description	Frequency (Hz)	Cadence *1	Signal level
Dial Tone	425	Continuous	-26dBm to -6.5dBm
Special Dial Tone	425 with 375	Continuous	-21dBm to -6.5dBm
Ringing Tone I	425	0.75(on)-7.5(off)	-43dBm to -6.5dBm
Ringing Tone II	425	1.0(on)-4.0(off)	-43dBm to -6.5dBm
Ringing Signal I	25	0.75(on)-7.5(off)	40Vac to 120Vac
Ringing Signal II	25	1.0(on)-4.0(off)	40Vac to 120Vac
Busy Tone I	425	0.45(on)-0.45(off)	-43dBm to -6.5dBm
Busy Tone II	425	0.25(on)-0.25(off)	-43dBm to -6.5dBm
Congestion Tone I	425	0.45(on)-0.45(off)	-43dBm to -6.5dBm
Congestion Tone II	425	0.25(on)-0.25(off)	-43dBm to -6.5dBm
SIT Tones	950	0.33(on)-[<0.03](off)	43dBm to -6.5dBm-
	1400	0.33(on)-[<0.03](off)	-43dBm to -6.5dBm
	1800	0.33(on)-1.0(off)	-43dBm to -6.5dBm
Metering Tones	12 000	[.075 to 0.12](on)- [>0.05](off)	-27dBm to +15dBm

Impedance: 600 Ω

fff/fff is defined because some exchanges use the first frequency and is the default, and other exchanges use the second frequency.

Finland Defaults

To make the settings for this country available, follow the instructions in “Importing Additional Countries” on page 41.

Description	Frequency (Hz)	Cadence *1	Signal level
Dial Tone	425	Continuous	-20dBm to -14dBm
Special Dial Tone	425	0.65(on)-0.025(off)	-20dBm to -14dBm
Centrex Dial Tone (PBX)	425	2x[0.2(on)-0.3(off)]-0.2(on)-0.8(off)	-20dBm to -14dBm
Ringing Tone	425	1.0(on)-4.0(off)	-20dBm to -14dBm
Ringing Signal	25	1.0(on)-4.0(off)	35Vac to 82.5Vac
Busy Tone	425	0.3(on)-0.3(off)	-20dBm to -14dBm
Reorder Tone	425	0.2(on)-0.2(off)	-20dBm to -14dBm
SIT Tones	950	0.33(on)-[<0.03](off)	-27dBm to -21dBm
1400	0.33(on)-[<0.03](off)	-27dBm to -21dBm	
1800	0.33(on)-1.0(off)	-27dBm to -21dBm	
Call Waiting Tone	425	0.15(on)-0.15(off)-0.15(on)-0.8(off)	-27dBm to -21dBm
CW (Informative) Tone	425	0.15(on)-8.0(off)	-27dBm to -21dBm
Metering Tones	16 000	0.15(on)-0.35(off)	0.24V to 8.0V

Impedance: 600 Ω

France Defaults

The settings for this country will be stored in configuration #4.

Dial Tone:
 Frequency: 440 Hz
 Level: -16 dBm
 Cadence: Continuous

Busy Tone:
 Frequency: 440 Hz
 Level: -16 dBm
 Cadence: 500 mS on/500 mS off

Reorder Tone:
 Frequency: 440 Hz
 Level: -16 dBm
 Cadence: 500 mS on/500 mS off

Ring Tone:
 Frequency: 400 Hz
 Level: -16 dBm
 Cadence: 1.5 S on/3.5 S off

Ring:ing:
 Frequency: 50 Hz
 Amplitude: 80 VRMS
 Cadence: 1.5 S on/3.5 S off

SIT or Number Unobtainable:
 Frequency: 950 Hz, 1400 Hz, 1800 Hz
 Level: -16 dBm
 Cadence: .3 S on/.02 S off/.3 S on/.02 S off/.3 S on/1 S off
 Comments: France uses SIT or recorded announcement,
 uses announcement as default

Call Waiting Tone:
 Frequency:
 Level:
 Cadence:
 Comments: Not used, disabled

Line Impedance: 600 Ω
 Line Reversal: Simple

Telephone Line Emulator User's Manual

Germany Defaults

The settings for this country will be stored in configuration #5.

Dial Tone:	
Frequency:	425 Hz
Level:	-14 dBm
Cadence:	Continuous
Busy Tone:	
Frequency:	425 Hz
Level:	-14 dBm
Cadence:	480 mS on/480 mS off
Reorder Tone:	
Frequency:	425 Hz
Level:	-14 dBm
Cadence:	240 mS on/240 mS off
Ringing Tone:	
Frequency:	425 Hz
Level:	-14 dBm
Cadence:	1 S on/4 S off
Ringing:	
Frequency:	25 Hz
Amplitude:	75 VRMS
Cadence:	1 S on/4 S off
SIT or Number Unobtainable:	
Frequency:	950 Hz, 1400 Hz, 1800 Hz
Level:	-14 dBm
Cadence:	.3 S on/.02 S off/.3 S on/.02 S off/.3 S on/1 S off
Comments:	Germany uses SIT or SIT followed by recorded announcement, uses announcement as default
Call Waiting Tone:	
Frequency:	
Level:	
Cadence:	
Comments:	Not used, disabled
Line Impedance:	Germany 220 Ω +(820 Ω 115nF)
Line Reversal:	Simple

Greece Defaults

To make the settings for this country available, follow the instructions in "Importing Additional Countries" on page 41.

Description	Frequency (Hz)	Cadence	Signal level
Dial Tone	425//450	0.2(on)-0.3(off)- 0.7(on)-0.8(off)	-25dBm to -4dBm
Ringing Tone	425//450	1(on)-4(off)	
Ringing Signal	16 to 50	1(on)-4(off)	25 to 90Vac
Busy Tone	425//450	0.3(on)-0.3(off)	
Reorder Tone	425	0.15(on)-0.15(off) or 0.3(on)-0.3(off)	
SIT Tones/N.U.T.	950	0.33(on)	
	1450	0.33(on)	
	1800	0.33(on)-1(off)	
Call Waiting Tone	425	0.3(on)-10(off) (twice)	
Metering Tones	16 000	0.05(on)-0.09(off)	-18dBm to +18dBm

Impedance: 600 Ω

fff//fff is defined because some exchanges use the first frequency and is the default, and other exchanges use the second frequency.

India Defaults

To make the settings for this country available, follow the instructions in "Importing Additional Countries" on page 41.

Description	Frequency (Hz)	Cadence *1
Dial Tone	33//50//400x25	Continuous
Ringing Tone I	400x25	0.4(on)-0.2(off)-0.4(on)- 2.6(off)
Ringing Tone II	133//400x25	0.4(on)-0.2(off)-0.4(on)- 2.0(off)
Busy Tone I	400	0.75(on)-0.75(off)
Busy Tone II	400	0.6(on)-0.6(off)
N.U.T. I	400	Continuous
N.U.T. II	400	2.5(on)-0.5(off)

fff//fff is defined because some exchanges use the first frequency and is the default, and other exchanges use the second frequency.

Ireland Defaults**The settings for this country will be stored in configuration #6.**

Dial Tone:	
Frequency:	400 Hz
Level:	-12 dBm
Cadence:	Continuous
Busy Tone:	
Frequency:	425 Hz
Level:	-12 dBm
Cadence:	500 mS on/500 mS off
Reorder Tone:	
Comment:	Same as Busy
Ringing Tone:	
Frequency:	400 Hz x 16 Hz (400 Hz modulated by 16 Hz)
Level:	-10 dBm
Cadence:	.4 S on/.2 S off/.4 S on/2 S off
Ringing:	
Frequency:	25 Hz
Amplitude:	75 VRMS
Cadence:	.4 S on/.2 S off/.4 S on/2 S off
SIT or Number Unobtainable:	
Frequency:	400 Hz
Level:	-10 dBm
Cadence:	6 S on/ 1 S off
Comments:	Ireland uses Number Unobtainable Tone
Call Waiting Tone:	
Frequency:	
Level:	
Cadence:	
Comments:	Not used, disabled
Line Impedance:	270 Ω + (750 Ω 150 nF) (TLE-PC Version 3.00 or greater)
Line Reversal:	Simple

Italy Defaults

To make the settings for this country available, follow the instructions in "Importing Additional Countries" on page 41.

Description	Frequency (Hz)	Cadence *1	Signal level
Dial Tone	425	0.2(on)-0.2(off)- 0.6(on)-1.0(off)	-25dBm to -6dBm
Special Dial Tone	425	Continuous	-25dBm to -6dBm
Ringing Tone	425	1.0(on)-4.0(off)	-43dBm to -6dBm
Ringing Signal	35	1.0(on)-4.0(off)	26Vac to 80Vac
Busy Tone	425	0.5(on)-0.5(off)	-43dBm to -6dBm
Reorder Tone	425	0.2(on)-0.2(off)	-43dBm to -6dBm
SIT Tones	950	0.33(on)- [<0.020](off)	-32dBm to - 15dBm
	1400	0.33(on)- [<0.020](off)	-32dBm to - 15dBm
	1800	0.33(on)-1.0(off)	-32dBm to - 15dBm
Metering Tones	12 000	0.125(on)-0.15(off)	65mV to 2.4V

Impedance: 600 Ω

Japan Defaults

The settings for this country will be stored in configuration #7.

Dial Tone:
 Frequency: 400 Hz
 Level: -15 dBm
 Cadence: Continuous

Busy Tone:
 Frequency: 400 Hz
 Level: -15 dBm
 Cadence: 500 mS on/500 mS off

Reorder Tone:
 Comment: Not used, will use busy

Ringling Tone:
 Frequency: 400 Hz
 Level: -15 dBm
 Cadence: 1s on/2 S off

Ringling:
 Frequency: 17 Hz
 Amplitude: 75 VRMS
 Cadence: 1s on/2 S off

SIT or Number Unobtainable:
 Comments: no SIT or Number Unobtainable tone per ITU
 will use announcement as default

Call Waiting Tone:
 Frequency: 400 X 16 Hz (400 Hz modulated by 16 Hz)
 Level: -15 dBm
 Cadence: .5 S on/.5 off/.5 on/ separated by 2.5 sec

Line Impedance: 600 Ω
 Line Reversal: Disabled

Telephone Line Emulator User's Manual

Korea Defaults

The settings for this country will be stored in configuration #8.

Dial Tone:	
Frequency:	350 Hz + 440 Hz
Level:	-10 dBm
Cadence:	Continuous
Busy Tone:	
Frequency:	480 Hz + 620 Hz
Level:	-10 dBm
Cadence:	500 mS on/500 mS off
Reorder Tone:	
Frequency:	480 Hz + 620 Hz
Level:	-10 dBm
Cadence:	300 mS on/200 mS off
Ringing Tone:	
Frequency:	440 Hz + 480 Hz
Level:	-10 dBm
Cadence:	1 S on/2 S off
Ringing:	
Frequency:	20 Hz
Amplitude:	80 VRMS
Cadence:	1 S on/2 S off
SIT or Number Unobtainable:	
Frequency:	450 Hz
Level:	-10 dBm
Cadence:	.2 S on/.1 S off/.2 S on/1.5 S off
Comments:	Korea uses recorded announcement or Number Unobtainable, uses announcement as default
Call Waiting Tone:	
Frequency:	350 Hz + 440 Hz
Level:	-10 dBm
Cadence:	.25 S on/.25 S off/.25 S on/3.25 S off
Line Impedance:	900 Ω
Comments:	Values based on US standard
Line Reversal:	Disabled

Netherlands Defaults**The settings for this country will be stored in configuration #9.**

Dial Tone:	
Frequency:	425 Hz
Level:	-10 dBm
Cadence:	Continuous
Busy Tone:	
Frequency:	425 Hz
Level:	-10 dBm
Cadence:	500 mS on/500 mS off
Reorder Tone:	
Frequency:	425 Hz
Level:	-10 dBm
Cadence:	250 mS on/250 mS off
Ringing Tone:	
Frequency:	425 Hz
Level:	-10 dBm
Cadence:	1 S on/4 S off
Ringing:	
Frequency:	25 Hz
Amplitude:	80 VRMS
Cadence:	1 S on/4 S off
SIT or Number Unobtainable:	
Frequency:	950 Hz, 1400 Hz, 1800 Hz
Level:	-14 dBm
Cadence:	.3 S on/.02 S off/.3 S on/.02 S off/.3 S on/1 S off
Comments:	Netherlands uses SIT or recorded announcement, uses announcement as default
Call Waiting Tone:	
Frequency:	425 Hz
Level:	-14 dBm
Cadence:	.5 S on/9.5 S off
Line Impedance:	600 Ω
Line Reversal:	Simple

Norway Defaults

To make the settings for this country available, follow the instructions in "Importing Additional Countries" on page 41.

Description	Frequency (Hz)	Cadence *1	Signal level
Dial Tone	425	Continuous	-30dBm to -3(+/-2)dBm
Centrex Dial Tone	425	0.6(on)-0.015(off)	-30dBm to -3(+/-2)dBm
Ringing Tone	425	1.0(on)-4.0(off)	-30dBm to -8(+/-2)dBm
Ringing Signal	25Hz	1.0(on)-4.0(off)	28Vac to 90Vac
Busy Tone	425	0.5(on)-0.5(off)	-30dBm to -8(+/-2)dBm
Congestion Tone	425	0.2(on)-0.2(off)	-30dBm to -8(+/-2)dBm
SIT Tones	950	0.33(on)-[<0.20](off)	-30dBm to -8(+/-2)dBm
	1400	0.33(on)-[<0.20](off)	-30dBm to -8(+/-2)dBm
	1800	0.33(on)-1.0(off)	-30dBm to -8(+/-2)dBm
Call Waiting Tone	1400	0.2(on)-2.0(off)- 2x[0.2(on)-90(off)]	-22dBm +/- 2dBm
Metering Tones	16 000	0.150(on)- [>0.120](off)	-25dBm to +7dBm

Impedance: (120+820//110nF) Ω

Singapore Defaults

The settings for this country will be stored in configuration #10.

Dial Tone:
 Frequency: 425 Hz
 Level: -15 dBm
 Cadence: Continuous

Busy Tone:
 Frequency: 425 Hz
 Level: -15 dBm
 Cadence: 750 mS on/750 mS off

Reorder Tone:
 Frequency: 425 Hz
 Level: -10 dBm
 Cadence: 250 mS on/250 mS off

Ring Tone:
 Frequency: 425 Hz X 24 Hz
 Level: -10 dBm
 Cadence: 0.4 S on/0.2 S off/0.4 S on/2 S off

Ringling:
 Frequency: 24 Hz
 Amplitude: 75 VRMS
 Cadence: .4 S on/.2 S off/.4 S on/2 S off

SIT or Number Unobtainable:
 Frequency: 425 Hz
 Level: -15 dBm
 Cadence: 2.5 S on/.5 S off
 Comments: SIT not used, uses Number Unobtainable tone

Call Waiting Tone:
 Frequency: 425 x 24 Hz (425 Hz modulated by 24 Hz)
 Level: -15 dBm
 Cadence: .3 S on/.2 S off/.3 S on/3.2 S off

Line Impedance: 600 Ω
 Line Reversal: Simple

Spain Defaults

To make the settings for this country available, follow the instructions in “Importing Additional Countries” on page 41.

Description	Frequency (Hz)	Cadence *1	Signal level
Dial Tone	425	Continuous	-20dBm to -5dBm
Special Dial Tone I	425	1.0(on)-0.1(off)	-20dBm to -5dBm
Special Dial Tone II	425	0.32(on)-0.02(off)	-20dBm to -5dBm
Ringing Tone I	425	1.5(on)-3.0(off)	-37dBm to -5dBm
Ringing Tone II	425	1.5(on)-2.9(off)	-37dBm to -5dBm
Ringing Tone III	425	1.5(on)-3.4(off)	-37dBm to -5dBm
Ringing Signal I	25	1.5(on)-3.0(off)	65Vac +/- 90Vac
Ringing Signal II	25	1.5(on)-2.9(off)	65Vac +/- 90Vac
Ringing Signal III	25	1.5(on)-3.4(off)	65Vac +/- 90Vac
Busy Tone	425	0.2(on)-0.2(off)	-35dBm to -5dBm
Reorder Tone	425	2x[0.2(on)-0.2(off)]- 0.2(on)-0.6(off)	-35dBm to -5dBm
SIT Tones	950	0.333(on)	-32dBm to -12dBm
	1400	0.333(on)	-35.5dBm to- 13dBm
	800	0.333(on)-1.0(off)	-39dBm to -14dBm
N.U.T.	25	0.2(on)-0.2(off)- 0.2(on)-0.6(off)	-35dBm to -5dBm
Call Waiting Tone	425	0.6(on)-0.2(off)- 0.6(on)-1.0(off)	-15dBm to -6dBm
Metering Tones	12 000	[>0.05](on)- [>0.05](off) 4.0V +/- 0.8V	

Impedance: 600 Ω

Sweden Defaults

The settings for this country will be stored in configuration #11.

Dial Tone:	
Frequency:	425 Hz
Level:	-15 dBm
Cadence:	Continuous
Busy Tone:	
Frequency:	425 Hz
Level:	-15 dBm
Cadence:	250 mS on/250 mS off
Reorder Tone:	
Frequency:	425 Hz
Level:	-15 dBm
Cadence:	250 mS on/750 mS off
Ringing Tone:	
Frequency:	425 Hz
Level:	-15 dBm
Cadence:	1 S on/5 S off
Ringing:	
Frequency:	25 Hz
Amplitude:	80 VRMS
Cadence:	1 S on/5 S off
SIT or Number Unobtainable:	
Frequency:	950 Hz, 1400 Hz, 1800 Hz
Level:	-20 dBm
Cadence:	3 S on/.02 S off/.3 S on/.02 S off/.3 S on/1 S off
Comments:	Sweden uses SIT followed by recorded announcement
Call Waiting Tone:	
Frequency:	425 Hz
Level:	-15 dBm
Cadence:	.2 S on/.5 off/.2 S on, one time only
Line Impedance:	270 Ω + (750 Ω 150 nF) *
Line Reversal:	Simple

*TLE-PC Version 3.00 or greater.

Switzerland Defaults

To make the settings for this country available, follow the instructions in "Importing Additional Countries" on page 41.

Description	Frequency (Hz)	Cadence	Signal level
Dial Tone	425 (1)	Continuous	-23dBm to 0dBm
Ringing Tone I	425 (1)	1.0(on)-4.0(off)	-33dBm to 6.5dBm
Ringing Tone II	425 (1)	0.5(on)-4.0(off)- 1.0(on)-4.0(off)	-33dBm to 6.5dBm
PBX Ringing Tone III	425 (1)	0.33(on)-0.33(off)- 0.33(on)-4.0(off)	-33dBm to 6.5dBm
Ringing Signal	25 to 50	1.0(on)-4.0(off)	25Vac to 90Vac
Busy Tone	425 (1)	0.5(on)-0.5(off)	-33dBm to - 6.5dBm
Reorder Tone	425	0.2(on)-0.2(off)	-33dBm to - 6.5dBm
SIT Tones/N.U.T.	950	0.3+/-0.04(on)	-33dBm to - 6.5dBm
1400	0.3+/-0.04(on)		-33dBm to -6.5dBm
1800	0.3+/-0.04(on), 1.0(off)		-33dBm to -6.5dBm
Call Waiting Tone	425	0.2(on)-0.2(off)- 0.2(on)-4(off)	
Metering Tones	12 000	[>0.05](on)- [>0.09](off)	110mV to 10V

(1) On older PBXs, these tones may be 500 Hz with exceptional 100 Hz.

Impedance: 220 Ω + (820 Ω // 115nF)

UK Defaults**The settings for this country will be stored in configuration #12.**

Dial Tone:
 Frequency: 350 Hz & 440 Hz
 Level: -12 dBm
 Cadence: Continuous

Busy Tone:
 Frequency: 400 Hz
 Level: -12 dBm
 Cadence: 375 mS on/375 mS off

Reorder Tone:
 Frequency: 400 Hz
 Level: -12 dBm (1st on in the cycle is 6 dB lower)
 Cadence: 400 mS on/350 mS off/225 mS on/525 mS off

Ring Tone:
 Frequency: 400 Hz + 450 Hz
 Level: -10 dBm
 Cadence: .4 S on/.2 S off/.4 S on/2 S off

Ringling:
 Frequency: 25 Hz
 Amplitude: 70 VRMS
 Cadence: .4 S on/.2 S off/.4 S on/2 S off

SIT or Number Unobtainable:
 Frequency: 400 Hz
 Level: -10 dBm
 Cadence: continuous

Call Waiting Tone:
 Frequency: 400 Hz
 Level: -12 dBm
 Cadence: 2 periods of .5 sec, separated by 10 sec

Line Impedance: United Kingdom 370 Ω +(620 Ω || 310nF)
 Line Reversal: Simple

Telephone Line Emulator User's Manual

US/Canada defaults

The settings for this country will be stored in configuration #1 and #13 through #16.

Dial Tone:

Frequency: 350 Hz + 440 Hz
Level: -13 dBm
Cadence: Continuous

Busy Tone:

Frequency: 480 + 620 Hz
Level: -24 dBm
Cadence: 500 mS on/500 mS off

Reorder Tone:

Frequency: 480 + 620 Hz
Level: -24 dBm
Cadence: 250 mS on/250 mS off

Ring Tone:

Frequency: 440 Hz + 480 Hz
Level: -19 dBm
Cadence: 2 S on/4 S off

Ring:

Frequency: 20 Hz
Amplitude: 70 VRMS
Cadence: 2 S on/4 S off

SIT or Number Unobtainable:

Frequency: 950 Hz, 1400 Hz, 1800 Hz
Level: -13 dBm
Cadence: .3 S on/.005 S off/.3 S on/.005 S off/.3 S on/.005 S off

Call Waiting Tone:

Frequency: 440 Hz
Level: -13 dBm
Cadence: 2 periods of .3 sec, separated by 10 sec

Line Impedance:

900 Ω

Line Reversal:

Disabled

International Caller ID Software Module (TLE-ICID)

Introduction

The TLE-ICID Software Module is designed as an upgrade to work in conjunction with the TLE-INTL Software Module. The TLE-ICID Software Module will support generation of Caller ID in both FSK and DTMF signaling formats in both an on-hook (Type 1) and off-hook (Type 2) transmissions. This module will allow the user to configure many parameters of the Caller ID signaling such that countries not configured by default in the TLE may be supported. Caller ID is also known as CLIP, Calling Line Identification Presentation, but will be referred in this document as Caller ID or CID. Visual Message Waiting is a special form of Caller ID used to inform a user that messages are waiting in a voice mailbox.

The programming of the TLE-ICID operating parameters is supported using multiple screens. Call Waiting and Caller ID were once separate screens, but have been combined in the TLE-ICID module.

Note: The various Caller ID devices and telephones display the Caller ID information in different ways. Please refer to the technical documents supplied by the manufacturer for details.



Teltone uses various technical references to determine the default values for specific countries. However, there are circumstances where a parameter may have several variations, or new standards may be announced. Consequently, each user must verify that the operating parameters are valid for their application and usage.

Overview - TLE-ICID

The basics of Caller ID are that after an Alerting Sequence, a specially formatted message is sent to a telephone or other adjunct device that will display the identity of the calling party. This may be sent while the telephone or adjunct are in an on-hook state (Type I signaling), or while they are in an off-hook state (Type II signaling).

In Type I signaling, the Alerting Sequence may be a Ring, Line Reversal, Open Switch Interval, Dual Tone, a combination of signals, or there may be no alerting signal. The formatted message may be sent as FSK or DTMF, and may contain only the time/date and telephone number of the calling party (Single Data Message Format, or SDMF) or it may contain the name of the calling party or other call details (Multiple Data Message Format, or MDMF).

In Type II signaling, the Alerting Sequence consists of a Subscriber Alerting Sequence (SAS, or Call Waiting Tone), followed by a CPE Alerting Sequence (CAS tone or Dual Tone Alerting Sequence). The telephone or adjunct responds to the alerting sequence with an acknowledgement signal, and then the Caller ID message is sent. The called party can then decide whether or not to answer the call, based upon the identity of the calling party. As in Type I signaling, the formatted message may contain only the time/date and telephone number of the calling party (Single Data Message Format, or SDMF) or it may

Telephone Line Emulator User's Manual

contain the name of the calling party or other call details (Multiple Data Message Format, or MDMF).

The TLE can emulate special Caller ID features (Private, Out of Area) and transmission errors (checksum error) by dialing a specific prefix prior to the telephone number.

The following countries in the TLE-ICID module have the appropriate default values loaded for Caller ID. These defaults are based upon technical reference documents. See the References for details.

Australia	Bellcore Plus FSK, Type 1 & 2
France	ETSI FSK, Type 1
Germany	ETSI FSK, Type 1
Netherlands	ETSI DTMF, Type 1
Singapore	Bellcore Plus FSK, Type 1
Sweden	ETSI DTMF, Type 1
UK	ETSI FSK, type 1 & 2
US/Canada	Bellcore FSK, Type 1 & 2

All other countries will have Caller ID disabled by default, but may be enabled by the user.



Figure 32. Type I - CID or CLIP Sequence of Events

Note: CID sequence Not Associated with Ringing is the same as above without RING.

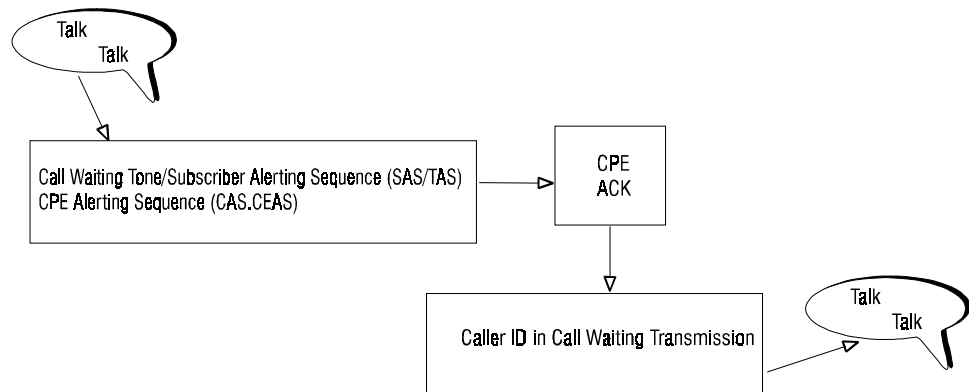

Figure 33. Type II - Caller ID in Call Waiting Sequence

Details of Operation

Caller ID can be broken down into two signaling standards, three types and two message formats. The two standards of signaling are DTMF and FSK. The DTMF signaling standard is defined as ETSI DTMF. FSK signaling standard will be broken into three groups, Bellcore, Bellcore Plus and ETSI FSK. Bellcore Plus is defined as a superset based upon the Bellcore standard and is currently in use by Australia and Singapore.

Type I Caller ID is an on-hook transmission.

Type II Caller ID is an off-hook transmission, also known as SCWID or CIDCW.

Type III Caller ID is an off hook interactive transmission, also known as ADSI (Analog Display Services Interface) or AST (Advanced Screen Telephony).

The two message formats are Single Data Message Format (Calling Number delivery), and Multiple Data Message Format (Calling Name and Number delivery).

The TLE currently supports only Type I and Type II signaling.

Caller ID Transmission Options - FSK Transmission

The TLE-ICID module supports 5 types of calls.

- “Normal” CID delivery,
- “Private” message delivery when a *67 (default) prefix is dialed,
- “Out of Area” message delivery when a *87 (default) prefix is dialed,
- CID Not Associated with Ringing delivery when a *50 or *51 prefix is dialed,
- Checksum error delivery when a *88 prefix is dialed.

Normal CID delivery will allow up to 9 parameters to be defined and transmitted. Private and Out of Area transmissions will allow up to 6 parameters to be defined and transmitted.

The Checksum error transmission will send the same information as the Normal CID delivery.

Transmission parameters will be entered into tables so that the order of transmission is changed by the order of each parameter in the table.

Caller ID Transmission Options - DTMF Transmission

The TLE-ICID module supports the following DTMF Transmissions, all associated with Ringing.

- Calling Number only
- Calling Number and Diverting Number
- Diverting Number only
- Calling Number, Diverting Number, Call Forward, and Information Code
- Private (restricted) code delivery when a *67 (default) prefix is dialed
- Out of Area (calling party unavailable) code when a *87 (default) prefix is dialed

By default the TLE transmits the following phone numbers:

- | | |
|-------------------|---|
| Calling Number: | Phone number assigned for Group 1 of the calling line |
| Diverting Number: | Phone number assigned for Group 3 of the calling line |
| Forward Number: | Phone number assigned for Group 2 of the calling line |

Caller ID Configuration

This is a per-line programmable parameter.

- Off, Caller ID in Call Waiting will also be disabled
- Single Data Message Format
- Multiple Data Message Format
- Bellcore
- Bellcore Plus
- ETSI DTMF
- ETSI FSK

Date and Time

The date and time is sent by the TLE as Month, Day, Hour, and Minute.

Normal Caller ID

The Normal Caller ID transmission can be programmed for up to 9 parameter types. The Caller ID in Call Waiting format selection is the same as the Normal CID parameters, if enabled.

Out of Area

The Out of Area transmission can be programmed for up to 6 parameter types. An Out of Area message can be issued by dialing a special prefix before the telephone number. The dialing prefix is programmable, up to 4 digits in length. The default is **87**.

Private

A Private transmission can be programmed for up to 6 parameter types. A Private message can be issued by dialing a special prefix before the telephone number. The dialing prefix is programmable, up to 4 digits in length. The default is **67**.

Checksum

The Checksum is a block of data used to detect an error in the Caller ID message. An artificial error can be introduced in the TLE by dialing a special prefix (**88**) before the telephone number. The TLE will transmit the same data block as a Normal transmission, but it will deliberately send an invalid checksum. Different products will display different messages, and some times no message, when this error occurs.

Call Waiting Type

Subscriber Alerting Signal (SAS) tone for Call Waiting is programmable with the following options:

- Call Waiting tone disabled.
- Normal (single) SAS tone, followed by CAS and CID if ACK seen, and CID is enabled.
- Distinctive (double) SAS tone, followed by CAS and CID if ACK seen, and CID is enabled.
- Normal (single) SAS tone, no CAS or CID will follow.
- Distinctive (double) SAS tone, no CAS or CID will follow.

When Distinctive SAS tones are selected, the TLE will send this tone when the dialed phone number is greater than 7 digits. Otherwise, the normal (single) tone will be sent.

Caller ID Timing Parameters

The following timing parameters are programmable within the TLE-ICID module. Please note that some timings are used in both DTMF and FSK signaling and the details are duplicated where appropriate.

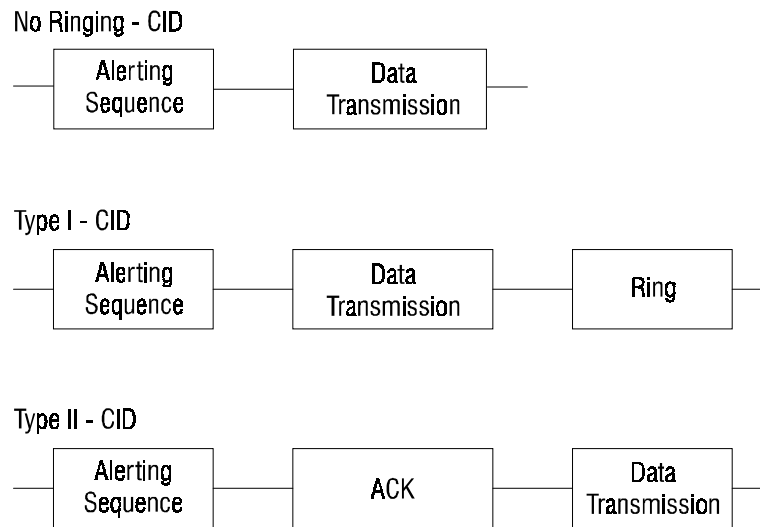

Figure 34. Timing Diagrams

DTMF Timing Parameters

The following parameters are programmable in the TLE-ICID module:

- Line Reversal to DTMF
- Ring to DTMF/FSK
- DTMF/FSK to Ring

See the following section for more details.

FSK Timing Parameters

The following parameters are programmable in the TLE-ICID module:

- Dual Tone to FSK
- Line Reversal to Dual Tone
- DTMF/FSK to Ring
- Ring to DTMF/FSK
- OSI to FSK
- On-hook Channel Seizure
- On-hook Mark Time
- Off-hook Mark Time
- Dual Tone Alerting Signal
- Ring Burst Alerting Signal

See the following section for more details.

Programming

The programming of the TLE-ICID operating parameters is supported using multiple screens. Call Waiting and Caller ID were once separate screens, but have been combined in the TLE-ICID Software Module. The TLE-ICID Software Module allows a user to program the Caller ID parameters for each line for greater flexibility. If only one **Caller ID Standard** is chosen, then parameters not associated with that Standard will not be able to be chosen. More advanced users have the option of choosing the **Caller ID Standard** "Everything" and have no restrictions in accessing all programming parameters.

Note: The **Defaults** button on each screen will reset the parameters for only the screen being edited. If a user wishes to reset all parameters for a configuration to **Defaults**, then use the **Defaults** button on the **Main TLE** screen.

Caller ID and Call Waiting Modes

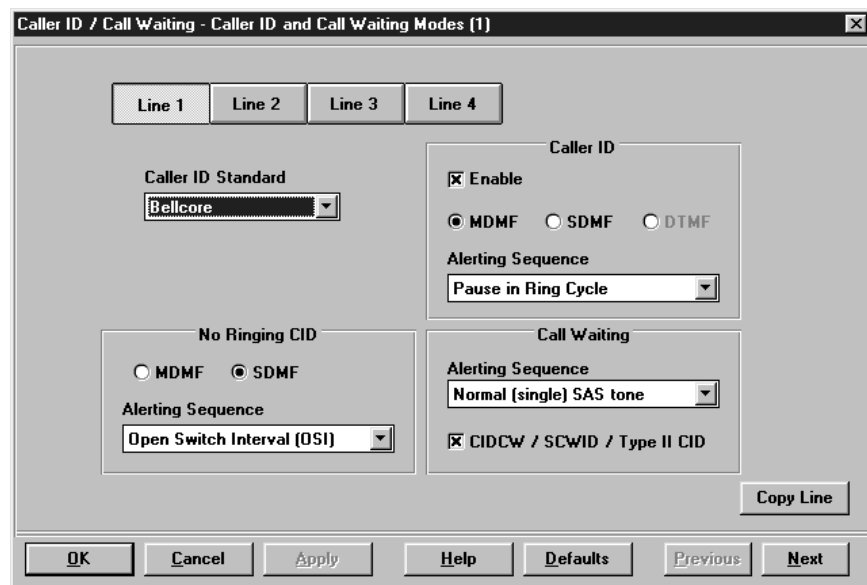

Figure 35. Caller ID/Call Waiting - Caller ID and Call Waiting Modes

The following Caller ID Standards may be selected:

- Bellcore
- Bellcore Plus
- ETSI DTMF
- ETSI FSK
- Everything

The standard(s) selected affect the options programmed on subsequent screens.



Selection of multiple standards or Everything requires the user to choose only those options appropriate to the **Caller ID Standard** for the line selected.

Caller ID

Options available are:

- Enable/Disable Caller ID

- Select the **Caller ID** message format:

- SDMF** (Single Data Message Format)

- MDMF** (Multiple Data Message Format)

- DTMF**

- Select the **Alerting Sequence**:

- Dual Tone

- None

- Pause in Ring Cycle

- Reversal

- Reversal (restores at Ring)

- Reversal + Dual Tone

- Ring Burst

Note: Not all Alerting Sequences are available for all Caller ID message formats.

No Ringing CID

No Ringing CID (or Caller ID not associated with ringing), is also commonly known as Message Waiting.

Options available are:

- Select the message format:

- SDMF** (Single Data Message Format)

- MDMF** (Multiple Data Message Format)

- Select the **Alerting Sequence**:

- Open Switch Interval (OSI)

- Ring Burst

- Dual Tone

- Reversal + Dual Tone

Note: Not all Alerting Sequences are available for all message formats.

Call Waiting

Options available are:

Select the **Alerting Sequence**:

Normal (single) SAS tone

Distinctive (double) SAS tone

Enable/Disable **CIDCW / SCWID / Type II CID**

If a valid Caller ID format is selected (Bellcore, Bellcore Plus, or ETSI FSK) is selected, and CIDCW / SCWID / Type II CID is enabled, then a CID transmission will occur if the proper DTMF acknowledgement tone (see Caller ID Miscellaneous Parameters Screen) is sent by a CID device within the proper time. The CIDCW (Caller ID on Call Waiting), SCWID (Spontaneous Call Waiting with Identification), Type II CID format is the same as the Normal CID transmission parameters, if enabled

Caller ID and CIDCW Components and Sequence

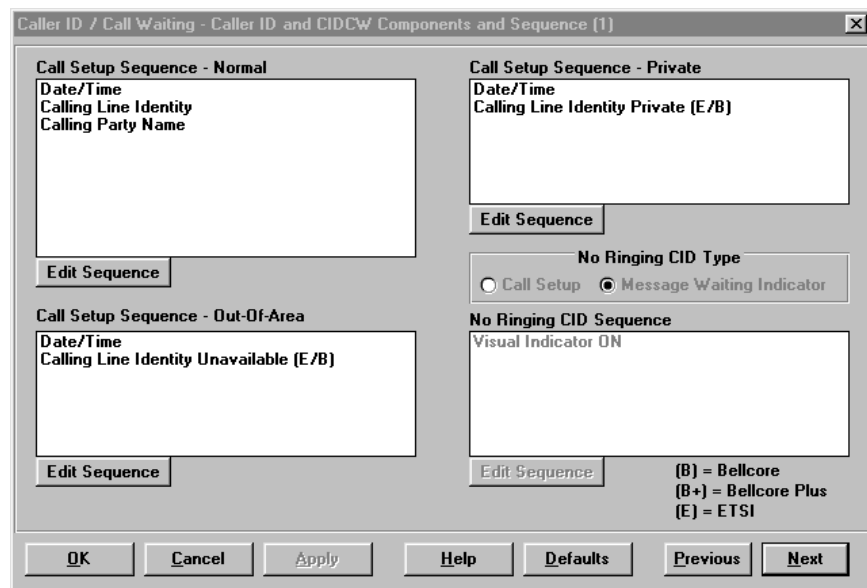

Figure 36. Caller ID/Call Waiting - Caller ID and CIDCW Components and Sequence

Note: This screen will be hidden if SDMF or ETSI DTMF format is selected for all lines. See Figure 35.

Single Data Message Format

SDMF format transmissions consist of the following fixed messages for each type of call:

Normal Call – Date/Time and Number

Private Call (*67 prefix by default) – Private Code

Out of Area Call (*87 prefix by default) – OTA Code

Message Waiting Indicator On (*50 prefix) – VMWI On code

Message Waiting Indicator Off (*51 prefix) – VMWI Off code

Multiple Data Message Format

MDMF format transmissions consist of the following messages for each type of call:

Normal Call – Up to nine user-selected Call Setup components (Call Setup Sequence – Normal)

Private Call (*67 prefix by default) – Up to six user-selected Call Setup components (Call Setup Sequence – Private)

Out of Area Call (*87 prefix by default) – Up to six user-selected Call Setup components (Call Setup Sequence – Out of Area)

Message Waiting Indicator On (*50 prefix) – Up to six user-selected Call Setup or Message Waiting components (No Ringing CID Sequence)

Message Waiting Indicator Off (*51 prefix) – VMWI Off code

Note: The following operation will only apply if the unit is configured for US/Canada operation; all other countries have as default, “Message Waiting” dial tone = continuous.

If the *50 prefix plus a phone number is dialed, the TLE will issue stuttered (“Message Waiting” dial tone on the called line. If the *51 prefix plus a phone number is dialed, the TLE will clear the stuttered dial tone on the destination line. Alternately, after a user dials the audio message (411 default) from a line which has “Message Waiting” dial tone active, the unit will revert back to normal dial tone and a Message Waiting OFF transmission will be sent.

Note: “Data transmission not associated with ringing” (No Ringing CID) is not specified for networks which use DTMF Caller ID transmission. If a user dials the *50 or *51 prefix when DTMF CID is specified, the TLE will send a FSK Message Waiting transmission.

The following lists show the Call Setup and Message Waiting message components from which the user may select for MDMF sequences. Which components are displayed depends upon which Caller ID standard(s) has been selected. If all four lines are set to the same standard, only those components listed for that standard will be displayed. If more than one standard has been selected, the displayed list will contain the components for all of the selected standards. If “Everything” is selected as a standard, the components for all of the standards will be displayed.

Any component unique to a particular standard will be noted:

B = Bellcore

B+ = Bellcore Plus

E = ETSI

MDMF Call Setup Message Components

Bellcore

Call Forward Busy (B/B+)

Call Forward Don't Answer (B/B+)

Call Forward Universal (B/B+)

Calling = Data Call

Calling = Mobile + Virtual Private Network

Calling = Mobile Phone

Calling = Ordinary Subscriber

Calling = Payphone

Calling = Priority Subscriber

Telephone Line Emulator User's Manual

Calling = Test Call
Calling = Unavailable or Unknown
Calling = Virtual Private Network
Calling Line Identity
Calling Line Identity Private (E/B)
Calling Line Identity Unavailable (E/B)
Calling Party Name
Calling Party Name Private
Calling Party Name Unavailable
Date/Time
Dialable Directory Number (B/B+)
Out-of-area, O in number field (B)
Private, P in number field (B)

Bellcore Plus

Call Forward Busy (B/B+)
Call Forward Don't Answer (B/B+)
Call Forward Universal (B/B+)
Call Qualifier = Long Distance (B+)
Calling = Data Call
Calling = Mobile + Virtual Private Network
Calling = Mobile Phone
Calling = Ordinary Subscriber
Calling = Payphone
Calling = Priority Subscriber
Calling = Test Call
Calling = Unavailable or Unknown
Calling = Virtual Private Network
Calling Line Identity
Calling Party Name
Calling Party Name Private
Calling Party Name Unavailable
Date/Time
Dialable Directory Number (B/B+)
Dialable Directory Number Private (B+)
Dialable Directory Number Unavailable (B+)

ETSI FSK

Call Forward Number (E)
Call Type = Call Name Delivery (E)
Call Type = Message Waiting (E)
Call Type = Ringback When Call Free (E)
Call Type = Voice Call (E)
Called Line Identity (E)
Calling = Data Call
Calling = Mobile + Virtual Private Network
Calling = Mobile Phone

Calling = Ordinary Subscriber
Calling = Payphone
Calling = Priority Subscriber
Calling = Test Call
Calling = Unavailable or Unknown
Calling = Virtual Private Network
Calling Line Identity
Calling Line Identity Private (E/B)
Calling Line Identity Unavailable (E/B)
Calling Party Name
Calling Party Name Private
Calling Party Name Unavailable
Complementary Calling Line Identity (E)
Date/Time
Extension For Network Operator Use (E)
Forwarded = Can't Reach Mobile (E)
Forwarded = Deflected after Alerting (E)
Forwarded = Deflected Immediate (E)
Forwarded = Forward on Busy (E)
Forwarded = Forward on No Reply (E)
Forwarded = Unavailable or Unknown (E)
Forwarded = Unconditional (E)
Network Message = 1 or Unspecified (E)
Network Message = No Messages (E)
Network Message = User Defined (E)
Redirecting Number Line Identity (E)
User Defined Item #1 (E)
User Defined Item #2 (E)
User Defined Item #3 (E)

MDMF Message Waiting Message Components

Bellcore or Bellcore Plus

Calling Line Identity
Calling Party Name
Calling Party Name Private
Calling Party Name Unavailable
Date/Time
Visual Indicator OFF
Visual Indicator ON

ETSI FSK

- Calling Line Identity
- Calling Line Identity Private (E)
- Calling Line Identity Unavailable (E)
- Calling Party Name
- Calling Party Name Private
- Calling Party Name Unavailable
- Date/Time
- Extension For Network Operator Use (E)
- Network Message = 1 or Unspecified (E)
- Network Message = No Messages (E)
- Network Message = User Defined (E)
- User Defined Item #1 (E)
- User Defined Item #2 (E)
- User Defined Item #3 (E)
- Visual Indicator OFF
- Visual Indicator ON

Caller ID Miscellaneous Parameters

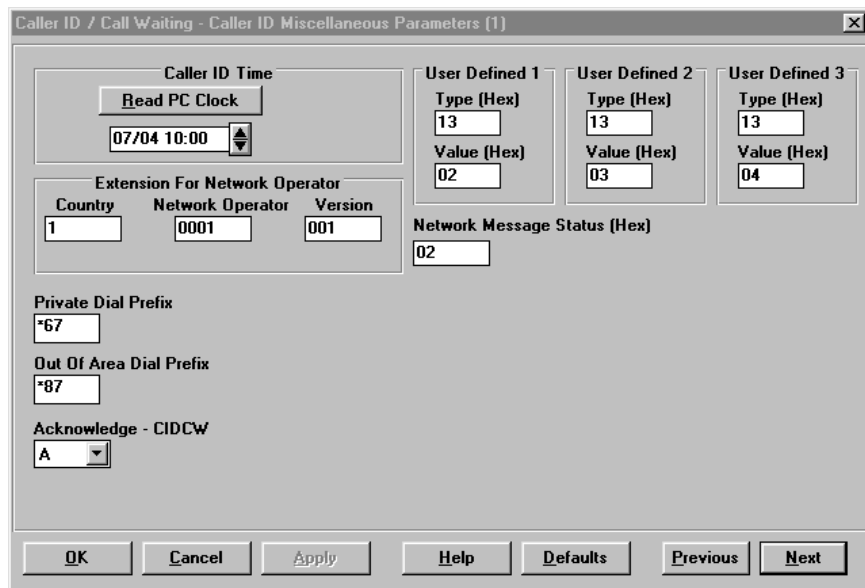

Figure 37. Caller ID/Call Waiting - Caller ID Miscellaneous Parameters

The TLE-ICID Software Module allows the user to program specific parameters for use in different standards and applications. These programmable parameters include setting the **Caller ID Time**, the **Extension for Network Operator**, a **Network Message Status**, three **User Defined** fields, the **Private** transmission **Dial Prefix**, the **Out of Area Dial Prefix**, and the DTMF **Acknowledge** digit for **CIDCW**.

The following are the values for parameters that are not country specific.

Network Message Status

Programmable as one of the following:

- 00H – no messages
- 01H – 1 or unspecified number of messages
- 02H to FFH – number of messages waiting

Extension for Network Operator

Defined as follows:

- 1st digit of country code (per ITU Q.11)
- 2nd digit of country code or space if no 2nd digit
- 3rd digit of country code or space if no 3rd digit
- Network Operator code (alphanumeric characters)
- Version code (alphanumeric characters)

User Defined Parameters

Up to 3 User Defined single byte parameters may be defined. These are to provide for the future addition of parameter types currently reserved. For each parameter the user must provide a parameter **Type** byte and a parameter **Value** byte.

Acknowledge - CIDCW

The TLE monitors for a DTMF “D” as an ACKnowledge digit. This is the Bellcore specified digit expected from a non-ADSI device. The TLE will also monitor for an alternate DTMF ACKnowledge digit, which is programmable. The default value is a DTMF “A”, which corresponds to the Bellcore specified digit expected from an ADSI device. The ETSI requirements state that a DTMF “D” must be accepted as a valid ACKnowledge digit, but that “A”, “B”, and “C” may be considered valid digits in some networks.

Phone Number Prefix and Group Selections

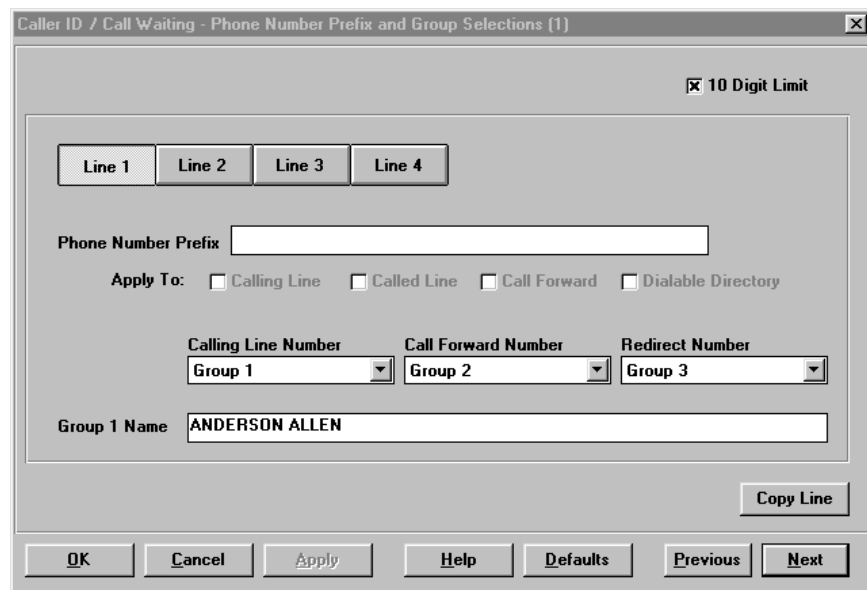

Figure 38. Caller ID/Call Waiting - Phone Number Prefix and Group Selections

Telephone Line Emulator User's Manual

The TLE-ICID module allows the user to program parameters such as setting a 10 digit limit (Bellcore phone number display standard), a Number Prefix (used to support display of numbers beyond 16 digits), which Group of Phone numbers are used for Calling Line, Call Forward, and Redirect Number display, and the ability to program the Group 1 Name to be displayed. These parameters are programmed individually for each Line.

Phone Number, also known as Calling Number / Calling Line Identity

The Calling Number sent to a Caller ID telephone or display unit can be of varying lengths. The telephone numbers in the TLE can be up to 16 digits in length. Some countries and formats require that fewer digits be sent or allow for a greater number of digits. For example, Australia FSK allows up to 64 characters, ETSI DTMF signaling allows up to 20 characters, Bellcore FSK allows up to 10 digits, and in the U.K. up to 18 digits are allowed. The TLE-ICID module will allow for up to 64 characters to be sent by using a special function called a "Prefix Number" along with the Telephone Number. The user can program Prefix Numbers for each of the 4 lines, which may be up to 48 characters long. Allowed characters are digits 0-9, asterisk "*", octothorpe "#", space " ", dash "-", left parentheses "(", and right parentheses ")". This prefix may be enabled or disabled for each line. This dial prefix will be enabled or disabled for each line for other functions such as **Calling Line Number**, **Call Forward Number**, and **Dialable Directory Number**. The Calling Number to be displayed is selected from one of the three groups of programmable phone numbers in the TLE.

Calling Party Name

The Calling Name in the TLE-ICID is programmable (Group 1 name only) and is limited to 64 characters. Group 2 and Group 3 names are fixed. The Calling Name is selected for each line from one of the three groups of names in the TLE. The default names for the 3 groups are as follows:

Group 1 - Programmable names, uses Group 1 phone numbers

Line 1 = ANDERSON ALLEN
Line 2 = JONES JENNIFER
Line 3 = SMITH SHARON
Line 4 = MACDONALD MIKE

Group 2 - Fixed names, uses Group 2 phone numbers

Line 1 = CLINTON BOB
Line 2 = REAGAN RICK
Line 3 = CARTER JOHNNY
Line 4 = FORD GARY

Group 3 - Fixed names, uses Group 3 phone numbers

Line 1 = MONTANA JIM
Line 2 = MARINO DON
Line 3 = AIKMAN TOM
Line 4 = KELLY JOHN

Calling Line Group Assignment	Group 1 Phone Numbers
Call Forward Group Assignment	Group 1 Phone Numbers
Redirect Number Group Assignment	Group 1 Phone Numbers
Calling Line Prefix Enable	Disable
Call Forward Prefix Enable	Disable
Dialable Directory Prefix Enable	Disable
Called Line Prefix Enable	Disable

Note: Caller ID phones and adjunct units may display some unique characters based upon national character sets. The characters displayed by the TLE_PC program are based upon the language settings of the Windows operating system and in most cases should match the characters used by the Caller ID box for a given country. Refer to the documentation for the Caller ID unit that you are using, the Windows operating system documentation, and CCITT Recommendation T.50 for more information.

Caller ID and Call Waiting Tones

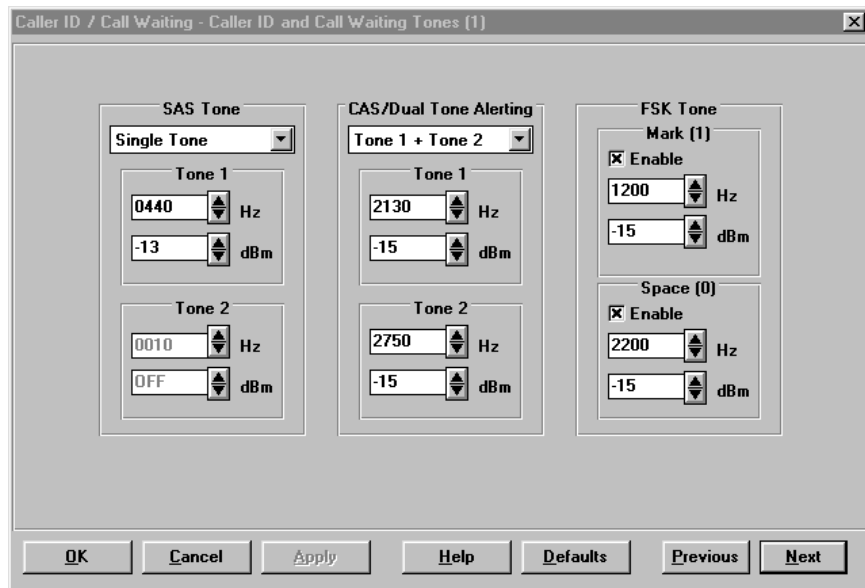

Figure 39. Caller ID/Call Waiting - Caller ID and Call Waiting Tones

The TLE-ICID module allows the user to configure the different parameters associated with the **SAS Tone**, **CAS / Dual Tone Alerting** (CPE Alerting Sequence or CIDCW) tone, and the **FSK Tones**.

SAS Tone

The Subscriber Alerting Sequence (SAS) or Call Waiting Tone is an Alerting Signal sent down a telephone line to inform a user that another call is waiting. The SAS tone is programmable as Disabled, Single Tone, Tone 1 + Tone 2 or Tone 1 x Tone 2. The frequency is programmable from 10 to 1800 Hz in 1 Hz increments and the signal level is programmable from -6 to -60 dBm in 1 dB increments.

CAS/Dual Tone Alerting

The CPE Alerting Sequence (CAS) tone is an Alerting Signal sent down the telephone line to inform CPE that a CIDCW/SCWID message is waiting. This CAS tone is sent after the SAS tone and will wait for a DTMF ACKnowledgement before transmitting CID data. The CAS tone is programmable as Disabled, Single Tone, Tone 1 + Tone 2 or Tone 1 x Tone 2. The frequency is programmable from 10 to 3000 Hz in 1 Hz increments and the signal level is programmable from -6 to -60 dBm in 1 dB increments.

FSK Tone(s)

The FSK tones are comprised of a Mark (1) and a Space (0) frequency. The Mark frequency may be set from 1100 Hz to 1400 Hz and the Space frequency from 2000 Hz to 2300 Hz in 1 Hz increments. The signal level for each frequency is programmable from -10 dBm to -60 dBm in 1 dB increments.

DTMF CID Parameters

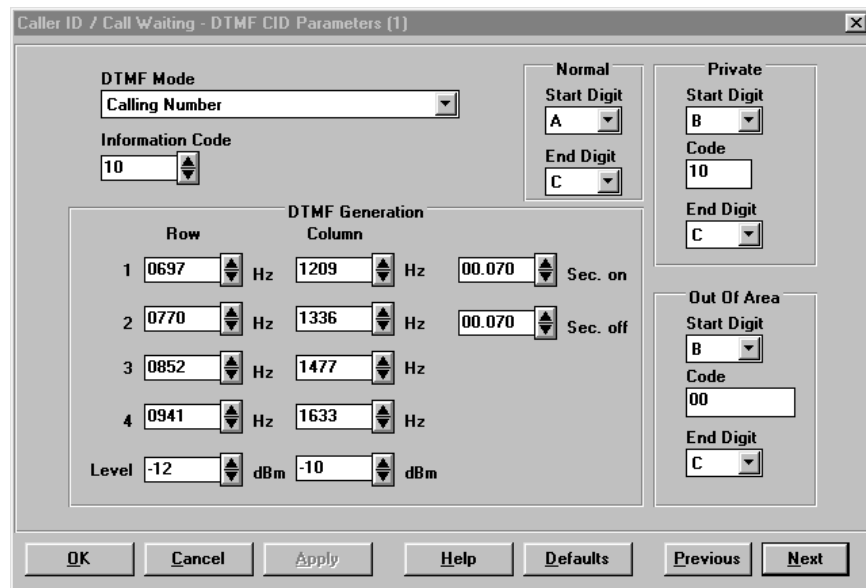

Figure 40. Caller ID/Call Waiting - DTMF CID Parameters

Note: This screen will be hidden if ETSI DTMF is NOT selected for any of the four Lines. See Figure 35.

The TLE-ICID module allows the user to configure many parameters associated with DTMF based Caller ID. These parameters include the **DTMF Mode**, **Information Code**, **Normal/Private/Out of Area** transmissions, and **DTMF Generation** details.

The **DTMF Mode** supports the following DTMF transmissions, all associated with Ringing:

- Calling Number only
- Calling Number and Diverting Number
- Diverting number only
- Calling Number, Diverting Number, Call Forward, and Information Code
- Private (restricted) code delivery when a *67 (default) prefix is dialed
- Out of Area (calling party unavailable) code when a *87 (default) prefix is dialed

The **Information Code** may be programmed to be any combination from 00 to 99. Currently Sweden uses 00 and 10 in their standard (see details below), with the balance reserved for future use. Any of the above modes may be overridden by dialing the prefix code ***67** or ***87** (default values) prior to the destination number. In this case the following special codes will be transmitted:

***67 Prefix:** Programmable code up to 2 digits, with programmable start and stop digits.

Defaults:

Sweden: Code: 10 (calling party number is restricted)
 Start digit: DTMF B
 Stop digit: DTMF C

Netherlands:

Not used (defaults = Sweden)

***87 Prefix:** Programmable code of up to 10 digits, with programmable start and stop digits.

Defaults:

Sweden: Code: 00 (calling number is not available)
 Start digit: DTMF B
 Stop digit: DTMF C
 Netherlands: Code: 0000000000 (calling party is unknown)
 Start digit: DTMF D
 Stop digit: DTMF C

The **Normal**, **Private**, and **Out of Area** transmissions (see Figure 6) have programmable Start and End digits as well as a programmable DTMF Code for the Private and Out of Area transmissions. See Figure 39 for more information.

DTMF Generation - Tone frequencies, Levels, and Timing

The DTMF tone frequencies are programmable from 100 to 2000 Hz in 1 Hz increments. The default values are set as seen below:

		Columns			
		1209	1336	1471	1633
Rows	697	1	2	3	A
	770	4	5	6	B
	852	7	8	9	C
	941	*	0	#	D

(Frequencies In Hz)

Figure 41. DTMF Parameters

The Row and Column signal levels are programmable from -6 to -60 dBm. The defaults of -12 dBm for the Row and -10 dBm for the Column tones are based on CEPT Recommendation, T/CS 46-02.

Timings

The DTMF tone timing is programmable from 0 to 1.0 Seconds ON and OFF in 5 mS increments.

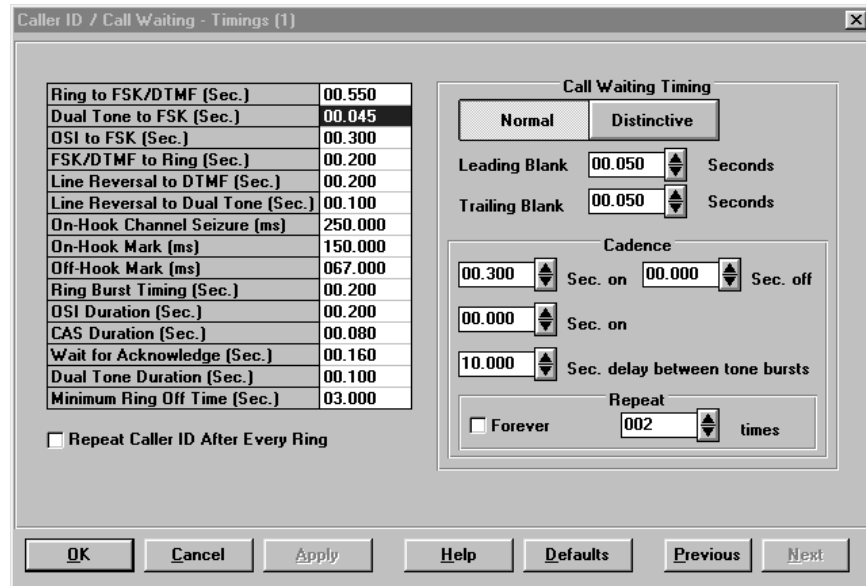

Figure 42. Caller ID/Call Waiting - Timings

The TLE-ICID module allows the user to configure many of the timing parameters that are associated with Caller ID, Caller ID with Call Waiting, Call Waiting, and Visual Message Waiting / Not Associated with Ringing Caller ID. Also programmable is the ability to **Repeat Caller ID After Every Ring**, a nice feature when troubleshooting applications using the “Pause in Ring Cycle” as the Alerting Sequence. This feature is not available for any other Alerting Sequence.

Note: The TLE supports individual ring generators for each line. The internal oscillators for these ring generators are asynchronous compared to the main TLE system clock. When a command is issued to turn Ringing “ON” or “OFF”, each ring generator will wait for a zero crossing point in their internal oscillators before turning “ON” or “OFF” the Ringing circuitry. The delay before a ring generator is turned “ON” or “OFF” is potentially one complete cycle of the ring frequency. For example, a 20 Hz ring frequency can result in up to a 50 mS (1 cycle / 20 Hz) delay before ringing starts. This detail must be considered when any timing parameter that is associated with ringing is changed.

Ring to DTMF/FSK

The time from the end of a **Ring** burst alerting signal or normal ring to the start of **FSK** or **DTMF** is programmable from 400 mS to 5 seconds in 5 mS increments.

Dual Tone to FSK

The time from the end of a **Dual Tone** Alerting Signal to the start of **FSK** is programmable from 40 mS to 5 seconds in 5 mS increments.

OSI to FSK

The time from the end of an **OSI** to the start of **FSK** transmission is programmable from 250 mS to 500 mS in 5 mS increments.

DTMF/FSK to Ring

The time from the end of **FSK** transmission to the start of the normal ring cycle, or from the end of a **DTMF** transmission to the start of the normal **Ring** cycle is programmable from 180 mS to 2 seconds in 5 mS increments.

Line Reversal to DTMF

The time from a **Line Reversal** to the start of **DTMF** CID transmission is programmable from 180 mS to 2 seconds in 5 mS increments.

Line Reversal to Dual Tone

The time from a **Line Reversal** to the start of **Dual Tone** Alerting signal is programmable from 90 mS to 5 seconds in 5 mS increments.

On-hook Channel Seizure

The length of the **On-hook Channel Seizure** signal is programmable from 50 mS to 500 mS. The Channel Seizure signal is an alternating bit pattern that corresponds to the transmission of multiple 55 Hex data bytes. Each data byte is 8.33 mS long, consequently, the default value is equal to the transmission of 30 bytes (250 mS / 8.33 mS = 30 bytes). When this timing value is adjusted, the TLE will select the number of full data bytes equal to the time chosen divided by 8.33 mS.

On-hook Mark Time

The **On-hook Mark** Signal is sent after the Channel Seizure and prior to the data portion of the CID transmission (Type I). The length of the **On-hook Mark** time is programmable from 40 mS to 200 mS in 125 μ S increments.

Off-hook Mark Time

The **Off-hook Mark** signal is sent after a valid ACK signal and prior to the data portion of the CID transmission (Type II). The length of the **Off-hook Mark** time is programmable from 40 mS to 200 mS in 125 μ S increments.

Ring Burst Alerting Signal

The length of the **Ring Burst Alerting** Signal is programmable from 150 mS to 320 mS in 5 mS increments.

OSI Duration

The OSI is a form of DC signaling, sent during an on-hook state, prior to Visual Message Waiting. During this time, the -48 VDC is momentarily removed. **OSI** may be set from 0 seconds to 5 seconds in 5 mS increments.

CAS Duration

CAS Tone is a CPE Alerting Signal; a Bellcore term for a tone used to alert CPE equipment of Call Waiting, asking for ACKnowledgement prior to sending Caller ID. The **CAS Duration** may be set from 70 mS to 90 mS in 5 mS increments.

Wait for Acknowledge

After the TLE sends the CAS signal it waits a certain time for a DTMF Acknowledgement signal from the CPE device. It sees this, it sends the FSK data. This **Wait for Acknowledgement** time may be varied to ensure that CPE devices are responding within the proper time window. **Wait for Acknowledgement** may be set from 100 mS to 300 mS in 5 mS increments.

Dual Tone Duration (DT-AS)

The length of the **Dual Tone Duration** is programmable from 85 mS to 115 mS in 5 mS increments.

Minimum Ring Off Time

By default, the TLE must see a minimum of 3 seconds in the off portion of the Ring Cadence, before Caller ID is sent. By programming this field to a shorter time, the user can force a transmission during shorter Ring Off Time. The user must be aware that for shorter times, the entire FSK data burst may not be complete before the next ring cycle. The **Minimum Ring Off Time** can be set from 0 seconds to 10 seconds. This feature only applies to the "Pause in Ring Cycle" Alerting Sequence.

Call Waiting Timing

Two Cadences are available: **Normal** and **Distinctive**.

The **Leading Blank** time is the time from when the existing call is muted and the Call Waiting starts. The **Trailing Blank** time is the time from when the Call Waiting stops and the existing call is reconnected.

Leading Blank, or the delay before the call waiting tone is sent, may be set from 5 to 100 mS off in 5 mS increments.

Trailing Blank, or the delay after the Call Waiting tone is sent, may be set from 20 to 100 mS off in 5 mS increments.

Cadence

On and **Off** times may be set from 0 mS to 1500 mS in 5 mS increments. The **delay between tone bursts** may be set from 1.000 S to 20.000 S in 5 mS increments.

Repeat

The Call Waiting Cadence may be repeated from 1 to 250 times. If **Forever** is selected the Call Waiting Cadence will be repeated until the originating caller goes on-hook.

Australia Defaults

These items will be preset in configuration #9. Refer to the TLE-INTL section for more details.

Dial Tone, Busy Tone, Reorder Tone, Ringing Tone, Ringing, SIT or Number Unobtainable, Call Waiting Tone (Subscriber alerting signal, SAS)

Reference Standard:	ACA TS 002
Call Waiting Type:	Normal (single) SAS tone, followed by CAS and CID if ACK seen
Line Impedance:	220 ohms + (820 ohms 120 nF)
CAS low tone:	2130 Hz @ -26 dBm (6 dB above min detect level for CPE)
CAS high tone:	2750 Hz @ -26 dBm
CAS duration:	80 mS
CAS wait for acknowledge	160 mS
CAS alternate acknowledge digit	DTMF A
FSK frequency	
Low tone (MARK)	1200 Hz
High tone (SPACE)	2200 Hz
Level	-28 dBm (6 dB above min detect level for CPE)

Caller ID Mode (Ringing)

Multiple Message Format; send after ring burst alerting signal; normal ringing follows

Normal CID Table Parameters (up to 9 maximum)

Date/Time
 Calling Line Identity
 Calling Party Name

Private CID Table Parameters (up to 6 maximum)

Date/Time
 Calling Party Name Private

Out of Area (OTA) CID Table Parameters (up to 6 maximum)

Date/Time
 Calling Party Name Unavailable

Dial Prefix for Private	*67
Dial Prefix for Out of Area (OTA)	*87
Calling Number 10 Digit Limit	Disabled
Prefix Number Line 1	15551
Prefix Number Line 2	15552
Prefix Number Line 3	15553
Prefix Number Line 4	15554

Message Type for CID not associated with ringing

Message Waiting Indicator

Mode for CID not associated with ringing

Multiple Message Format, sent after OSI
 OSI time = 0, disabled

Parameters for CID not associated with ringing (up to 6 maximum)

Visual Indicator On

Timers

Ring end to FSK	550 mS
DTMF/FSK end to ring start	200 mS
OSI timer length	0 seconds, no OSI generated
On-hook channel Seizure	250 mS
On-hook Mark length	150 mS
Off-hook Mark length	67 mS
Ring burst	200 mS
Ring Cadence Group 1	.4 sec on/.2 sec off/.4 sec on/ 2 sec off
Ring Cadence Group 2	.8 sec on/.4 sec off/.8 sec on/ 4 sec off
Ring Cadence Group 3	1 sec on/1 sec off/1 sec on/ 3 sec off

France Defaults

These items will be preset in configuration #9. Refer to the TLE-INTL section for more details.

Dial Tone, Busy Tone, Reorder Tone, Ringing Tone, Ringing, SIT or Number Unobtainable, Call Waiting Tone (Subscriber alerting signal, SAS)

Call Waiting Type:	Call Waiting tone disabled
FSK frequency	
Low tone (MARK)	1300 Hz
High tone (SPACE)	2100 Hz
Level	-28 dBm
Caller ID Mode (Ringing)	
	Multiple Message Format; sent after ring burst alerting signal; normal ringing follows
Normal CID Table Parameters (up to 9 maximum)	
	Date/Time
	Calling Line Identity
	Calling Party Name
	Call Type = voice call
Private CID Table Parameters (up to 6 maximum)	
	Date/Time
	Calling Line Identity Private
	Calling Party Name Private
Out of Area (OTA) CID Table Parameters (up to 6 maximum)	
	Date/Time
	Calling Line Identity Unavailable
	Calling Party Name Unavailable
Network Message Status	00H = no messages
Extension for Network Operator:	
Country	33 (France)
Network Operator	0001
Version	001
Dial Prefix for Private	#31#
Dial Prefix for Out of Area (OTA)	*87
Calling Number 10 Digit Limit	Disabled
Prefix Number Line 1	1-555-1
Prefix Number Line 2	1-555-2
Prefix Number Line 3	1-555-3
Prefix Number Line 4	1-555-4
Message Type for CID not associated with ringing	
	Message Waiting Indicator
Mode for CID not associated with ringing	
	Multiple Message Format, sent after ring burst alerting signal
Parameters for CID not associated with ringing (up to 6 maximum)	
	Visual Indicator On
	Date/Time
	Calling Line Identity
	Calling Line Name

Timers

Ring end to FSK	550 mS
DTMF/FSK end to ring start	200 mS
On-hook channel Seizure	250 mS
On-hook Mark length	150 mS
Off-hook Mark length	67 mS
Ring burst	250 mS
Ring Cadence Group 1	1.5 sec on/3.5 sec off
Ring Cadence Group 2	.8 sec on/.4 sec off/.8 sec on/ 4 sec off
Ring Cadence Group 3	1 sec on/1 sec off/1 sec on/ 3 sec off
User message #1	Set to: 13H,2;network status = 2 messages
User message #2	Set to: 13H,3;network status = 3 messages
User message #3	Set to: 13H,4;network status = 4 messages

Germany Defaults

These items will be preset in configuration #9. Refer to the TLE-INTL section for more details.

Dial Tone, Busy Tone, Reorder Tone, Ringing Tone, Ringing, SIT or Number Unobtainable, Call Waiting Tone (Subscriber alerting signal, SAS),

Call Waiting Type:	Call Waiting tone disabled
FSK frequency	
low tone (MARK)	1300 Hz
high tone (SPACE)	2100 Hz
level	-28 dBm
Caller ID Mode (Ringing)	
Multiple Message Format; send after ring burst alerting signal; normal ringing follows	
Normal CID Table Parameters (up to 9 maximum)	
Date/Time	
Calling Line Identity	
Calling Party Name	
Call Type = voice call	
Private CID Table Parameters (up to 6 maximum)	
Date/Time	
Calling Line Identity Private	
Calling Party Name Unavailable	
Out of Area (OTA) CID Table Parameters (up to 6 maximum)	
Date/Time	
Calling Line Identity Unavailable	
Calling Party Name Unavailable	
Network Message Status	00H = no messages
Extension for Network Operator	
Country	49 (Germany)
Network Operator	0001
Version	001
Dial Prefix for Private	*67
Dial Prefix for OTA	*87
Calling Number 10 Digit Limit	Disabled
Prefix Number Line 1	1-555-1
Prefix Number Line 2	1-555-2
Prefix Number Line 3	1-555-3
Prefix Number Line 4	1-555-4
Timers	
Ring end to FSK	550 mS
DTMF/FSK end to ring start	200 mS
On-hook channel Seizure	250 mS
On-hook Mark length	150 mS
Off-hook Mark length	67 mS
Ring burst	250 mS
Ring Cadence Group 1	1 sec on/4 sec off
Ring Cadence Group 2	.8 sec on/.4 sec off/.8 sec on/ 4 sec off

Ring Cadence Group 3
User message #1
User message #2
User message #3

1 sec on/1 sec off/1 sec on/ 3 sec off
Set to: 13H,2;network status = 2 messages
Set to: 13H,3;network status = 3 messages
Set to: 13H,4;network status = 4 messages

Netherlands Defaults

These items will be preset in configuration #9. Refer to the TLE-INTL section for more details.

Dial Tone, Busy Tone, Reorder Tone, Ringing Tone, Ringing, SIT or Number Unobtainable, Call Waiting Tone (Subscriber alerting signal, SAS),

Call Waiting Type: Normal (single) SAS tone, no CID will follow
 Caller ID Mode (Ringing)

Dial Prefix for Private DTMF format, sent after initial line reversal, then back to previous polarity at start of ring.
 *67 (Using Bellcore default, have not identified a specific prefix for the Netherlands)

Dial Prefix for OTA *87

Calling Number 10 Digit Limit Disable

Prefix Number Line 1 0;"interlocal" access code

Prefix Number Line 2 0

Prefix Number Line 3 0

Prefix Number Line 4 0

DTMF row & column levels Row = -12 dBm

Column = -10 dBm

DTMF transmission type Calling Number Only

DTMF On/Off time 70 mS

Timers:

DTMF/FSK end to ring start 200 mS

Line reversal to DTMF 300 mS

Ring Cadence Group 1 1 sec on/4 sec off

Ring Cadence Group 2 .8 sec on/.4 sec off/.8 sec on/ 4 sec off

Ring Cadence Group 3 1 sec on/1 sec off/1 sec on/ 3 sec off

Singapore Defaults

These items will be preset in configuration #9. Refer to the TLE-INTL section for more details.

Dial Tone, Busy Tone, Reorder Tone, Ringing Tone, Ringing, SIT or Number Unobtainable, Call Waiting Tone (Subscriber alerting signal, SAS)

Call Waiting Type:	Normal (single) SAS tone, no CID will follow
FSK frequency	
low tone (MARK)	1200 Hz
high tone (SPACE)	2200 Hz
level	-28 dBm (6 dB above min detect level for CPE)

Caller ID Mode (Ringing)
 Multiple Message Format; sent during first long pause in ring cycle, normal ringing follows

Normal CID Table Parameters (up to 9 maximum)

Date/Time
 Calling Line Identity
 Calling Party Name

Private CID Table Parameters (up to 6 maximum)

Date/Time
 Calling Party Name Private

Out of Area (OTA) CID Table Parameters (up to 6 maximum)

Date/Time
 Calling Party Name Unavailable

Dial Prefix for Private	*67
Dial Prefix for Out of Area (OTA)	*87
Calling Number 10 Digit Limit	Disabled
Prefix Number Line 1	15551
Prefix Number Line 2	15552
Prefix Number Line 3	15553
Prefix Number Line 4	15554

Timers

Ring end to FSK	550 mS
On-hook channel Seizure	250 mS
On-hook Mark length	150 mS
Off-hook Mark length	67 mS

Ring Cadence Group 1	.4 sec on/.2 sec off/.4 sec on/ 2 sec off
Ring Cadence Group 2	.8 sec on/.4 sec off/.8 sec on/ 4 sec off
Ring Cadence Group 3	1 sec on/1 sec off/1 sec on/ 3 sec off

Sweden Defaults

These items will be preset in configuration #9. Refer to the TLE-INTL section for more details.

Dial Tone, Busy Tone, Reorder Tone, Ringing Tone, Ringing, SIT or Number Unobtainable, Call Waiting Tone (Subscriber alerting signal, SAS)

DTMF row level	-12 dBm
DTMF column level	-10 dBm
DTMF on/off time	70 mS
DTMF transmission type	Calling Number Only
Line Impedance:	270 ohms + (750 ohms 150 nanofarads)
Call Waiting Type:	Normal (single) SAS tone, no CID will follow
Caller ID Mode (Ringing)	DTMF format, sent after initial line reversal then back to previous polarity at start of ring.
Dial Prefix for Private	*67 "Calling Party is Restricted"
Dial Prefix for OTA	*87 "Calling Party is Not Available"
Calling Number 10 Digit Limit	Disabled
Prefix Number Line 1	clear
Prefix Number Line 2	clear
Prefix Number Line 3	clear
Prefix Number Line 4	clear
Timers	
DTMF/FSK end to ring start	200 mS
Line reversal to DTMF	200 mS
Ring Cadence Group 1	1 sec on/5 sec off
Ring Cadence Group 2	.8 sec on/.4 sec off/.8 sec on/ 4 sec off
Ring Cadence Group 3	1 sec on/1 sec off/1 sec on/ 3 sec off

UK Defaults

These items will be preset in configuration #9. Refer to the TLE-INTL section for more details.

Dial Tone, Busy Tone, Reorder Tone, Ringing Tone, Ringing, SIT or Number Unobtainable, Call Waiting Tone (Subscriber alerting signal, SAS)

CAS low tone:	2130 Hz @ -26 dBm
CAS high tone:	2750 Hz @ -26 dBm
CAS duration:	80 mS
CAS wait for acknowledge	160 mS
CAS alternate acknowledge digit	DTMF D (i.e. both the default and programmable acknowledge signals are the same, digit D)

FSK frequency	
low tone (MARK)	1300 Hz
high tone (SPACE)	2100 Hz
level	-28 dBm

Caller ID Mode (Ringing)
 Multiple Message Format; send after line reversal and dual tone alerting signal; normal ringing follows

Normal CID Table Parameters (up to 9 maximum)

 Call Type = voice call
 Date/Time
 Calling Line Identity
 Calling Party Name

Private CID Table Parameters (up to 6 maximum)

 Call Type = voice call
 Date/Time
 Calling Line Identity Private
 Calling Party Name Private

Out of Area (OTA) CID Table Parameters (up to 6 maximum)

 Call Type = voice call
 Date/Time
 Calling Line Identity Unavailable
 Calling Party Name Unavailable

Absence of Name = "O"

Network Message Status 00H = no messages

Extension for Network Operator:

Country	44 (UK)
Network Operator	0001
Version	001

Dial Prefix for Private 141

Dial Prefix for OTA *87

Calling Number 10 Digit Limit Disabled

Prefix Number Line 1 1-555-1

Prefix Number Line 2 1-555-2

Prefix Number Line 3 1-555-3

Prefix Number Line 4 1-555-4

Telephone Line Emulator User's Manual

Message Type for CID not associated with ringing
Call Setup

Mode for CID not associated with ringing
Multiple message format; sent after line reversal and dual alerting tone

Parameters for CID not associated with ringing (up to 6 maximum)
Call Type = message waiting call
Date/time
Network message system status = 1 message

Timers

Ring end to FSK	550 mS
Dual tone to FSK	50 mS
Line reversal to dual tone	100 mS
DTMF/FSK end to ring start	200 mS
On-hook channel Seizure	250 mS
On-hook Mark length	150 mS
Off-hook Mark length	67 mS
Dual tone length	100 mS

Ring Cadence Group 1	.4 sec on/.2 sec off/.4 sec on/ 2 sec off
Ring Cadence Group 2	.8 sec on/.4 sec off/.8 sec on/ 4 sec off
Ring Cadence Group 3	1 sec on/1 sec off/1 sec on/ 3 sec off
User message #1	Set to: 13H,2 ;network status = 2 messages
User message #2	Set to: 13H,3 ;network status = 3 messages
User message #3	Set to: 13H,4 ;network status = 4 messages

US/Canada Defaults

These items will be preset in configuration #9. Refer to the TLE-INTL section for more details.

Dial Tone, Busy Tone, Reorder Tone, Ringing Tone, Ringing, SIT or Number Unobtainable, Call Waiting Tone (Subscriber alerting signal, SAS)

Reference Standard: Bellcore GR-30-CORE, TR-NWT-000031,
TR-NG-001188, TR-NWT-001401

Call Waiting Type: Normal (single) SAS tone, followed by CAS
and CID if ACK seen

Line Impedance: 900 ohms

CAS low tone: 2130 Hz @ -15 dBm

CAS high tone: 2750 Hz @ -15 dBm

CAS duration: 80 mS

CAS wait for acknowledge 160 mS

CAS alternate acknowledge digit DTMF A

FSK frequency

Low tone (MARK) 1200 Hz

High tone (SPACE) 2200 Hz

Level -15 dBm

Caller ID Mode (Ringing)

Multiple Message Format; send after first pause in ring cycle

Normal CID Table Parameters (up to 9 maximum)

Date/Time

Calling Line Identity

Calling Party Name

Private CID Table Parameters (up to 6 maximum)

Date/Time

Calling Line Identity Private

Out of Area (OTA) CID Table Parameters (up to 6 maximum)

Date/Time

Calling Line Identity Unavailable

Dial Prefix for Private *67

Dial Prefix for Out of Area (OTA) *87

Calling Number 10 Digit Limit Enabled

Message Type for CID not associated with ringing

Message Waiting Indicator

Mode for CID not associated with ringing

Single Message Format, sent after OSI

Parameters for CID not associated with ringing (up to 6 maximum)

Visual Indicator On

Telephone Line Emulator User's Manual

Timers

Ring end to FSK	550 mS
DTMF/FSK end to ring start	200 mS
OSI timer length	0.200 S
On-hook channel Seizure	250 mS
On-hook Mark length	150 mS
Off-hook Mark length	67 mS
Ring burst	200 mS
Ring Cadence Group 1	2.0 sec on/4.0 sec off
Ring Cadence Group 2	.8 sec on/.4 sec off/.8 sec on/ 4 sec off
Ring Cadence Group 3	1 sec on/1 sec off/1 sec on/ 3 sec off

References

ITU Fascicle II.2 Recommendation E.180, Supplement #2, 1/94

Telephone Network and ISDN - Operation, Numbering, Routing, and Mobile Services; Various Tones Used in National Networks

Technical Standard 002, Dec 1997, Australian Communications Authority

Analogue Interworking and Non-interference Requirements for Customer Equipment Connected to the Public Switched Telephone Network Technical Standard 30, 1997, Australian Telecommunications Authority, Requirements for Customer Equipment with an Analogue Data Interface Connected to the Public Switched Telephone Network

British Standard BS 6305: 1992

General requirements for apparatus for connection to the public switched telephone network run by certain public telecommunications operators SIN 227, Nov. 1997, British Telecom document: CDS, Calling Line Identification Service, Service Description SIN 242 Issue 2, Nov. 1996, British Telecom document, CDS, Calling Line Identification Service, Terminal Equipment Requirements

ETSI 300-001, March 1992, ETSI, European Telecommunications Standard

Attachments to the Public Switched Telephone Network; General technical requirements for equipment connected to an analogue interface in the PSTN ETS 300 659-1, Feb. 1997, ETSI document: Public Switched Telephone Network (PSTN); Subscriber Line Protocol over the local loop for display (and related) services; Part 1: On-hook data transmission ETS 300 659-2, Sept. 1997, ETSI document: Public Switched Telephone Network (PSTN); Subscriber Line Protocol over the local loop for display (and related) services; Part 2: Off-hook data transmission

ETS 300 778-1, Sept. 1997, ETSI document

Public Switched Telephone Network (PSTN); Protocol over the local loop for display and related services; Terminal Equipment Requirements, Part 1: Off-line data transmission

ETS 300 778-2, Jan. 1998, ETSI document

Public Switched Telephone Network (PSTN); Protocol over the local loop for display and related services; Terminal Equipment Requirements, Part 2: On-line data transmission

T 11-12E, Netherlands Hoofddirectie Telecommunicatie en Post

Conformity Specification for Terminal Equipment Intended for Connection to the Dutch Public Switched Telephone Network, Calling Line Indication Presentation

Singapore TAS TS PSTN 1, Issue 3 Rev 4, 1 April 1997

Approval Specification for terminal equipment for connection to Public Switched Telephone Network & Analogue Leased Circuits TAS TS PSTN 1 A-CLIP, Rev 1, Oct. 15 1996, Telecommunications Authority of Singapore document:

Analogue Calling Line Identity Presentation Facility for connection to Public Switched Telephone Network Swedish Specification TVT 8211-A 112E

Technical requirements for connection of subscriber equipment to the public switched telephone network 8211 A-331, Feb. 15, 1995, Telia (Swedish Telecom) document: Transfer of numbering information on analogue exchange line, incoming call 1056-A 763, June 18, 1998, Telia (Swedish Telecom) document: Transmission requirements for sending DTMF for CLI (Calling Line Identification)

The following web site URL's were used and are supplied for your convenience.

Standards Australia Online: <http://www.standards.com.au/default.htm>

SINet (British Telecom): <http://www1.btwebworld.com/sinet/index.htm>

ETSI (European Telecommunications Standards Institute) homepage: <http://www.etsi.org/>

France Telecom (research division): <http://www.cnet.fr/a/welcome.html>

Deutsche Telecom (Germany): <http://www.dtag.de/>

KNP (Royal Dutch Telecom): <http://www.kpn.com/research/en/route.html>

ITU (International Telecommunications Union): <http://www.itu.ch/>

Telecommunication Authority of Singapore: <http://www.tas.gov.sg>

Telia (Swedish Telecom): <http://www.telia.se/>

Automated Test Software Module (TLE-TEST)

The TLE-TEST module for the TLE-A-01 replaces the TLE-BASE, TLE-ADV, and TLE-INTL software in the TLE hardware for those users who need total control over the operation of their Emulator. The new features/functions include the ability to control and program the features of the TLE-BASE, TLE-ADV, and TLE-INTL modules via the serial port using an external program, or internally, using 1, 2, or 4 user programmable scripts.

The TLE-ICID module features are also available by installing both the TLE-INTL and TLE-ICID modules. These two modules along with the TLE-TEST module must all be installed on the TLE to enable International Caller ID features.

Included in the TLE-TEST module is an updated TLE-PC software module (see the new features further in this chapter) and an API (Applications Programming Interface) with examples written in Visual Basic and C++. The TLE-TEST uses simple ASCII strings to program/operate the TLE hardware, which makes it compatible with ANY operating system that supports RS232 serial operation.

Features included with the TLE-TEST module:

Complex Impedance

The TLE Loop Parameters were upgraded in the TLE-INTL module in TLE_PC software release version 2.00. This upgrade, to the TLE Loop Parameters, has added complex impedance's for Australia, Germany, and the United Kingdom. These parameters are loaded into the programmable SLIC used in the TLE. The details include:

Australia: $220 \Omega + (820\Omega \parallel 120\text{nF})$
Germany: $220 \Omega + (820\Omega \parallel 115\text{nF})$
(This complex impedance is also used for Switzerland.)
Sweden: $270 \Omega + (750 \Omega \parallel 150 \text{ nF})$ (TLE-PC Version 3.00 or later)
(This complex impedance is also used in Ireland.)
United Kingdom: $370 \Omega + (620\Omega \parallel 310\text{nF})$

Automated Test Screen

Under the **TLE Main** screen menu, there is a new sub menu called **Automated Test**. Upon selecting this option, a window appears with the following options.

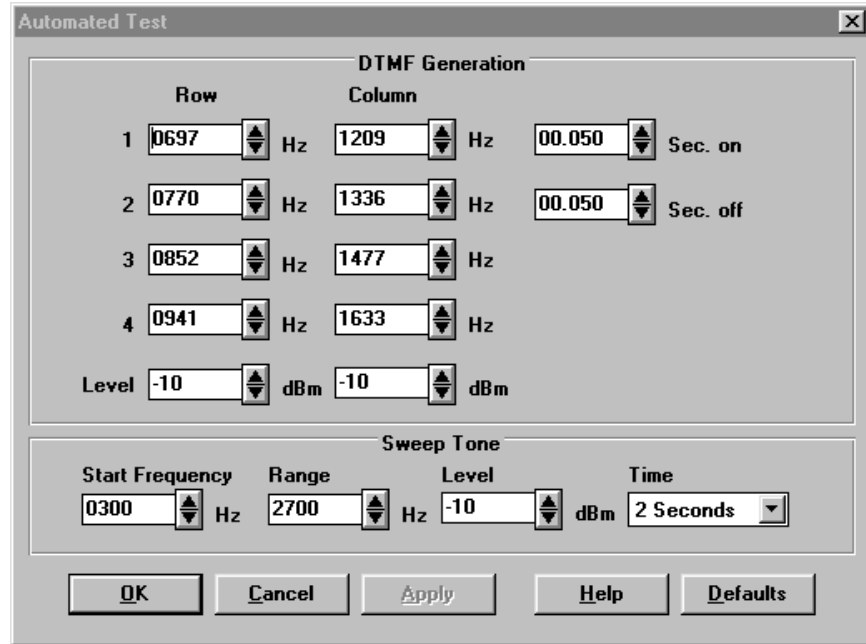

Figure 43. Automated Test Screen

DTMF Generation

The **DTMF Generation** feature allows for the setting of the frequency, signal level, and on/off timing for the **Row** and **Column** tones generated by a DTMF keypad. These tone pairs include 1-9,0,#,*,A,B,C, and D. The TLE-TEST module allows for the user to send a DTMF string to a Line by using command `TC_SENDDTMF,dtmf string,linenum`.

Sweep Tone

The **Sweep Tone** feature is an additional Test Tone similar to the ones seen in **Phone Numbers** screen and allows for the setting of the **Start Frequency**, **Range**, **Level**, and **Time**. The TLE-TEST module allows for the user to send a Sweep Tone to a Line using command `TC_SENDDTONE,tonename,linenum[,fromline]`.

Revision History

Version 1.00 TLE-Base - Initial Release

TLE_PC.EXE	09/23/97
TLE_PC	V1.00
BIOS	V1.00
DSP	V1.00
MCU	V1.00

Version 1.01 TLE-ADV - Advanced Simulation Module Release

TLE_PC.EXE	10/10/97
TLE_PC	V1.01
BIOS	V1.00
DSP	V1.00
MCU	V1.01

Changes: Networked Operating Systems Win95 and WinNT use a copy of MSCOMM.VBX that is incompatible with Visual Basic 3.0 and caused an error to be displayed during startup of the Configuration software. Version 1.01 solves this problem.

Additions: None

Version 1.02 TLE-INTL - International Module Release

TLE_PC.EXE	11/20/97
TLE_PC	V1.02
BIOS	V1.00
DSP	V1.00
MCU	V1.02

Changes: Corrected the **Invalid Number Response** in the **Miscellaneous** Screen to match the operation of **SIT + Audio**.

Additions: **Busy**, **Call Waiting**, **CAS Tone**, **Dial Tone**, **Reorder**, **Ringback**, and **Test Tone** screens were upgraded to allow for the addition of tone modulation, which is used by some international configurations. An extra window above the frequency and signal level settings allows for the setting of "**Tones**", which includes the option of **Disabled**, **Single Tone**, or **Tone 1 +Tone 2** operation. The addition in the International Module supports **Tone 1 X Tone 2**.

The **SIT** Screen was upgraded to **SIT / Number Unobtainable Tone**, which is used in some International configurations. When **Number Unobtainable Tone** is selected, the options under **Miscellaneous**, **Invalid Number Response** changes accordingly by removing the **SIT** options and replacing them with the **Number Unobtainable Tone** option.

The **Miscellaneous Screen**, **Invalid Number Response**, was upgraded to add **SIT Repeating**, which is used in some international configurations.

The **Call Waiting** Screen - **Country Code** option was removed. Replacing the Country Code option, the Cadence window was expanded to support a "**delay between tone bursts**" in 5 mS increments and a **Repeat** option was added. This increased flexibility should support all **Call Waiting** configurations.

All users can preview the features of the TLE-ADV and TLE-INTL modules off-line. This is accomplished off-line (not connected to the TLE or the TLE is turned off) by selecting **File**, then **New Configuration Set** and then selecting the **International** and/or the **Advanced Emulation** options. Attempts to program options not purchased will result in an error message when a TLE is connected via the serial port.

Version 1.03	TLE_PC.EXE	3/2/98
	TLE_PC	V1.03
	BIOS	V1.00
	DSP	V1.00
	MCU	V1.02

Bug fix: On some screens, the APPLY button would be activated, even though no changes were made.

Bug Fix: Dial Tone screen, changes made were not always displayed correctly.

Bug Fix: Saved file compatibility problem with TLE-ADV software module.

Version 2.00	TLE-TEST - Automated Test Software Module Release	
	TLE_PC.EXE	6/11/98
	TLE_PC	V2.00
	BIOS	V1.00
	DSP	V2.00
	MCU	V1.03 (TLE-TEST=V2.00)

Changes: Upgrade Three-Way-Calling feature to allow originator of Three-Way-Calling to bring all three parties together, although the third party has not answered. Upgrade serial port interface to fix a Windows NT 4.0 connection problem. A new communications port configuration window allows for easier installation and testing of the serial port connection.

Additions: Dialed digits are now displayed on the front panel for each Line.

TLE-BASE - The Active Configuration is now selectable via the serial port using ASCII strings.

TLE-INTL - Complex impedances for UK, Germany, and Australia were added.

A new feature is available as an item under the **File** menu option. This new option, **Reconfigure**, allows users who purchase the TLE-TEST module to switch between Automated Test operation and Standard operation. Also added is the ability to install an upgrade (such as TLE-ADV or TLE-INTL) while the TLE is not connected at the time of the installation. Once the TLE is connected to the PC, select, **File, Reconfigure - New Upgrade** to download the new software to the TLE.

Version 2.01	TLE_PC.EXE	10/8/98
	TLE_PC	V2.01
	BIOS	V1.00
	DSP	V2.00
	MCU	V1.03 (TLE-TEST=V2.00)

Bug Fix: Defaults for Singapore Busy timing were incorrect and have been corrected to 750 ms on/750 ms off.

Telephone Line Emulator User's Manual

Version 3.00 TLE-ICID - International Caller ID Software Module release

TLE_PC.EXE	10/8/98
TLE_PC	V3.00
BIOS	V1.00
DSP	V2.10
MCU	V3.00 (TLE-TEST=V2.00)

Upgrades: TLE Help file upgraded. TLE-BASE - **Copy Line** feature added to **Ring** screen for easier programming and the **Edit Configuration** number is now included as part of the Title Bar on every programming screen (in parentheses). Example: Dial Tone (1). TLE-INTL - Complex impedance for Sweden added.

Version 3.01 TLE_PC.EXE 6/04/99

TLE_PC	V3.01
BIOS	V1.00
DSP	V2.10
MCU	V3.00 (TLE-TEST V2.00)

Bug Fix: International Windows applications (Regional Settings) using the delimiter " , " instead of the decimal point " . " caused some values to be reset to 0.000.

Version 3.02 TLE_PC.EXE 10/19/1999

TLE_PC	V3.02
BIOS	V1.00
DSP	V2.10
MCU	V3.00 (TLE-TEST V2.00)

Version 3.02 incorporates several bug fixes for items identified since the 3.01 release, including problems with the saving of single configurations, as well as a new installation program to install properly on Windows 95/98 machines which sometimes have a problem with rogue setup1.exe files.

Version 3.03 TLE_PC.EXE 3/24/2000

TLE_PC	V3.03
BIOS	V1.00
DSP	V2.10
MCU	V3.00 (TLE-TEST V2.01)

Version 3.03 incorporates new microcontroller code for TLE-TEST which corrects problems in detecting dialing in test scripts.

Version 3.04 TLE_PC.EXE 8/2/2000

TLE_PC	V3.04
BIOS	V1.00
DSP	V2.10 (TLE-TEST V2.30)
MCU	V3.00 (TLE-TEST V2.20)

Upgrades: Addition of ICID functionality with TLE-TEST.

Version 3.05 TLE_PC.EXE 9/25/01

TLE_PC	V3.05
BIOS	V1.00
DSP	V2.10 (TLE-TEST V2.30)
MCU	V3.00 (TLE-TEST V2.20)

Changes: Incorporates all country configurations available into software install.

Bug Fix: Run Time error occurred when all modules installed.

Troubleshooting

Note: Downloadable software updates are available on Teltone's website at www.teltone.com.

Please report any error messages not found in this section to Teltone Technical Support.

Errors on Power-up

- Problem:** No display appears when power turned on.
Solution: Check Status LED on front panel. If lit, call Teltone Customer Service for assistance. If the LED is off, check power connection. If power connection is good, and LED is still off, contact Teltone Customer Service for assistance.
- Problem:** "No Program Found, Download Program" is displayed.
Solution: Connect a PC to the TLE using the serial cable provided. Start the TLE Configuration Software and follow the online download instructions.
- Problem:** "No DSP Code Found, Download Program" is displayed.
Solution: Connect a PC to the TLE using the serial cable provided. Start the TLE Configuration Software and follow the online download instructions.
- Problem:** The TLE will not complete boot process.
Solution: Upon normal power up, the TLE will boot by checking various components within the unit. The following are the standard messages that will display:
1. Teltone TLE
 2. Testing Program
 3. Initializing DSP System
 4. Testing PCM Controller
 5. Testing Line Circuits
 6. Active Configuration #
 7. On Hook On Hook
 On Hook On Hook

As the unit powers up it displays the various system messages, but also queues line messages. During this time as the line circuits are initialized, a momentary off-hook condition may be recognized, and entered into the display queue. This can result in a momentary "off-hook" and "dial tone" message being displayed. This is normal.

If the TLE stops this boot process at any stage and does not proceed, call Teltone Customer Service at 425-951-3388 for assistance.

- Problem:** Running Windows NT and the PC does not recognize that a TLE is connected to the serial port.
- Solution:**
1. Check to make sure the TLE is powered up and running.
 2. Check the serial port connections.
 3. Check the TLE PC software version number, found under the Help - About screen. If the TLE PC version number is not 2.00 or greater, call Teltone customer service or access Teltone's web site at www.teltone.com for information on how to get new software.
- Problem:** A Line is reporting off-hook all the time.
- Solution:** An internal component has been damaged causing the off-hook failure. The TLE must be returned to the factory for repair. Contact Teltone Customer Support for an MRA (Material Return Authorization) number.

Informational and Error Messages

The following are the Informational and Error messages generated by the TLE_PC program as of version 1.02. This list does not contain Visual Basic and Windows System error messages which may be displayed while running the TLE_PC program.

Defaults File

- Error Message:** Default file "filename" not found or wrong type. Program will continue with defaults unavailable.
- Explanation:** The file with the default values for the current configuration type has been deleted or corrupted. To recover the file the user should re-install the software.

Configuration Error Messages

- Error Message:** Current Edit Configuration in PC does not match the stored configuration in the TLE. Do you wish to upload the current configuration in the TLE and overwrite the existing Edit Configuration?
- Explanation:** When an Edit configuration is selected on the main screen, the program compares it to the corresponding configuration in the TLE (if one is connected). If the configuration in the TLE does not match the configuration in the PC, this message is displayed to inform the user and give him the opportunity to synchronize his file with the unit.
- Error Message:** The TLE currently connected is incompatible with the configuration set being edited. You may continue to work off-line. To connect to the unit, save your current configuration set, then select File New from the menu.
- Explanation:** If a configuration set for an upgraded TLE (i.e.: international) is being edited, and the user connects a TLE which has not been upgraded, the software will prevent the user from sending the upgraded configuration to the TLE. The user can continue to work off-line and save the configuration, then connect to the TLE by selecting "File", "New Configuration Set".

Error Message: The current configuration of your unit might not be valid, or may require an upgrade to the TLE_PC software. For the latest version of TLE_PC software, see Teltone's web site at www.teltone.com. Do you wish to reconfigure the unit to a compatible version now?

Explanation: The TLE_PC software has detected a combination of Boot Code, Microcontroller Code and DSP Code versions which are not listed in its current list of compatible versions. This could be due to a corrupted code in the TLE, or newer code having been downloaded to it while connected to a different PC.

Reconfiguring the unit will download the latest compatible versions of microcontroller and/or DSP code which are on that PC.

Note: Newer versions of TLE_PC software are compatible with all previous TLE configurations. It is recommended that users always install the latest version of TLE_PC software on all systems which they use to configure TLEs.

Error Message: Not active in this configuration.

Explanation: Selecting items in the "Find" dialog which are not compatible with the configuration type being edited will result in this message.

Miscellaneous Error Messages

Error Message: "SIT + Audio" and "SIT Repeating" cannot both be selected. If you wish to select "SIT + Audio", you must first remove all selections for "SIT Repeating" from the other lines.

Error Message: "SIT + Audio" and "SIT Repeating" cannot both be selected. If you wish to select "SIT Repeating", you must first remove all selections for "SIT + Audio" from the other lines.

Explanation: The above two messages are displayed if the user attempts to program the "Response to Invalid" for different lines to both "SIT + Audio" and "SIT Repeating". These two selections are mutually exclusive.

Audio Related Error Messages

Error Message: Total length of all messages must not exceed 8 seconds. The current total is "x" seconds.

Explanation: The user has selected voice files which total more than 8 seconds in length (voice file lengths are rounded up to the nearest half second). The user must select voice files which total no more than 8 seconds.

Error Message: File "filename" has changed and the total length of all messages now exceeds 8 seconds. The current total is "x" seconds.

Explanation: A voice file which had previously been selected has been edited and/or replaced by a file which is longer than the original, and the total of all selected messages now exceeds 8 seconds. The user must select voice files which total no more than 8 seconds.

Error Message: File "filename not found!" (Audio File)

Explanation: A previously selected voice file cannot be found in the audio subdirectory of the TLE_PC program.

Error Message: Wrong File Type! File must be Mono 8.000 kHz 8-bit mu-law wave file.

Explanation: A WAV file has been selected which is not compatible with the TLE.

Upgrade Error Messages

Error Message: An upgrade to "upgrade type" is available for this unit. Do you wish to download now?

Explanation: When a user has installed an upgrade package and upgrade key (i.e.: Advanced Simulation, International, etc.) the program compares the key to the TLE when a TLE is connected. When the key and TLE are validated, the program displays this message, allowing the user to either upgrade the TLE at that time, or postpone the upgrade. If the user chooses to upgrade the TLE at that time, the program will download new microcontroller and DSP code to the TLE if necessary, and upgrade the TLE with new software.

Note: If the TLE has had a previous upgrade installed, the new upgrade will be added to the TLE (i.e.: if previously upgraded to Advanced Simulation, and now upgrading to International, the TLE will be upgraded with both Advanced Simulation and International features).

Error Message: Programming this unit requires an update to the TLE_PC Software.

Explanation: The TLE has been upgraded (i.e.: to Advanced Simulation and/or International), and is connected to a PC which has a version of the TLE_PC software which does not support the upgrade. The user should install the upgrade software on all PC's to which the upgraded TLE is connected.

Note: Newer versions of TLE_PC software are compatible with all previous TLE configurations. It is recommended that users always install the latest version of TLE_PC software on all systems which they use to configure TLEs.

Error Message: Newer code is available for this unit. Do you wish to download now?

Explanation: Newer Microcontroller and/or DSP code has been installed on the PC and is available to be downloaded to the TLE. The normal response is YES.

Communication Port Errors

Error Message: The selected port is unavailable or in use by another application. Please select another port, or close the other application.

Explanation: The serial communications port which is selected in the program is not available to be used by the TLE_PC program. Verify which port the TLE is connected to, and select that port for configuring the TLE, and close all other applications which are currently using that port.

Telephone Line Emulator User's Manual

Error Message: Port Timeout Error. Please check that the TLE is properly connected to your PC and powered up.

Explanation: Communications to the TLE have failed. Verify the TLE is still connected to the port, and has power.

Error Message: TLE not responding. Retry?

Explanation: A communications error has occurred while sending data to the TLE. Retrying will attempt to resend the data to the TLE.

File Errors

Error Message: File "filename" is not compatible with the TLE that is currently connected.

Explanation: The file being opened contains a configuration set for a TLE with upgraded features for which the current TLE has not had the upgrade installed.

Error Message: File "filename" is not a TLE Configuration Set file.

Explanation: The file being opened is not a TLE configuration file.

Error Message: Error occurred during download.

Explanation: An error occurred while downloading a microcontroller or DSP code file, or a voice message. The user should re-attempt the download.

Error Message: TLE must be idle before starting download. Go on-hook with all phones and retry.

Explanation: The TLE does not support calls while downloading microcontroller or DSP code files, or voice messages. The user should go on-hook on all phones connected to the TLE and wait for all lines to be idle (display shows "On hook" for all lines) and then re-attempt the download.

Error Message: File "filename" not found! (Audio File)

Explanation: See Audio Related Error Messages.

Error Message: Wrong File Type! File must be Mono 8.000kHz 8-bit mu-law wave file.

Explanation: See Audio Related Error Messages.

Telephone Wiring Variants

The wiring for the RJ-11 connections is based upon Bellcore standards with the signaling on pins 3 and 4 of the 6 pin modular connector. Some countries, such as the U.K., need special wiring to operate correctly.

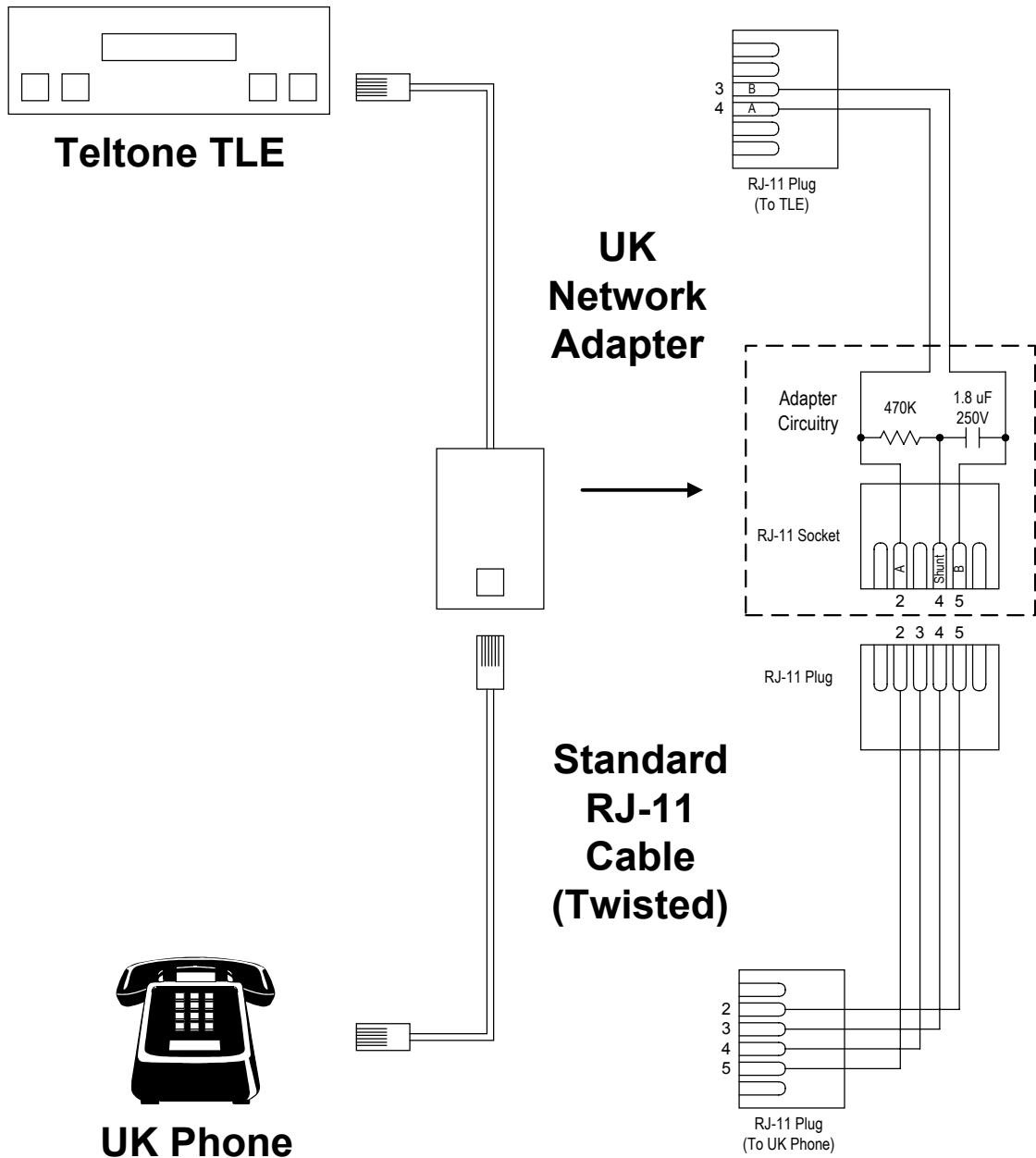

Figure 44. UK Phone Wiring Diagram

Warranty and Service

Warranty Information

Teltone warrants the Telephone Line Emulator to be free of defects in workmanship and materials for a period of 2 years. The warranty expiration date is evidenced by a label on each unit that states "Warranty date: Month/Year". This is the date the warranty expires.

Return Procedures

If a unit is found to be defective, contact Teltone Customer Service at 425-951-3388 to obtain an MRA (Material Return Authorization) number and shipping instructions. When returning units, provide the following information:

- Unit model number, unit part number, and serial number (obtained from the rear panel ID label).
- Teltone MRA number
- All available fault information
- Complete shipping and billing address
- Repair purchase order

Technical Assistance

For technical assistance on this product, call Teltone Technical Support at 425-951-3390 or send an email to support@teltone.com.

Maintenance

Cleaning

The TLE may be cleaned by using a damp cloth and wiping away any dust or residue on the metal. Use only water or a mild cleaner on the display screen. Always disconnect power before cleaning the TLE.

Servicing

The TLE should be checked periodically for damage or hazardous conditions. There are no user-serviceable parts except for the line fuse.

Ordering Information

For details on how to order or to receive pricing information, call Teltone Customer Service at 425-951-3388.

TLE-A-01	Four port, two voice path, test emulator with screen display. Includes Windows-based configuration software, DB9F to DB9M Cable, DB9M to DB25F adapter, and power cord.
CA-7F	Modular cord, 7 foot. 6-position to 6-position modular cord.
CA-25F	Modular cord, 25 foot. 6-position to 6-position modular cord.
TLE-BASE	Replacement Base Configuration Software. Included with each TLE-A-01 when shipped.
TLE-ADV	Advanced Emulation Software Module. Software module upgrade that allows testing of echo, white noise, satellite delay, signal level measurement, and metering tones.
TLE-INTL	International Software. Software module upgrade that allows testing of call progress and dial tones from 12 different countries, including: Australia, Canada, Ireland, Netherlands, Sweden, United Kingdom, France, Japan, Germany, Singapore, Taiwan, and Korea.
TLE-ICID	International Caller ID Software Module. Software module upgrade to TLE-INTL that provides International Caller ID protocols used in Australia, France, Germany, the Netherlands, Singapore, Sweden, U.K., and other countries using FSK and DTMF based Caller ID. Requires the TLE-INTL Software Module.
TLE-TEST	Automated Test Software. Software module upgrade that allows automation of testing by using the serial port to control the TLE. Advanced Simulation and International functionality is included. International Caller ID functionality is available and requires the TLE-INTL and TLE-ICID Software Modules.
40-400-00020	TLE-A-01 User's Manual.
40-400-00025	TLE-TEST Automated Test Software User's Manual.

Technical Specifications

AC Power	100-240 VAC, 50/60 Hz 0.6A
Fuse (User Serviceable)	T2.0H (Time delay, 2 A, high interrupt capability), 5 X 20 mm, 2 ea.
Telephone Interface	
Loop Current	10 to 70 mA in 1 mA increments \pm 10%
Battery Source	48 VDC \pm 5 V
Ringing Source	20 - 80 VAC in 5 V increments, sinusoidal waveform
Ring Source Accuracy	+0 - 5V
Ring Trip	> off-hook detect time
Ring Cadence	up to 3 cycles set in 5 mS increments
on cycle	0 - 3.0 S in 5 mS increments
off cycle	0 - 10 S in 5 mS increments
Ring Frequency	17 - 70 Hz in 1 Hz increments
Impedance	600 Ω + 2.2 μ F or 900 Ω + 2.2 μ F
Complex Impedances	Australia 220 Ω +(820 Ω 120nF) Germany 220 Ω +(820 Ω 115nF) Sweden 270 Ω + (750 Ω 150 nF) (Version 3.00+) United Kingdom 370 Ω + (620 Ω 310nF)
Insertion Loss	4.0 +/- 1.0 dB @ 1000 Hz when both ports are terminated into the selected impedance
Attenuation	4 to 60 dB in 1 dB steps
Off-hook Detect Time	100 to 3000 mS in 5 mS increments
On-hook Detect Time	100 to 3000 mS in 5 mS increments
On/Off-hook Detect Flash	75 mS to 1200 mS in 5 mS increments
Line Reversal	50 mS to 1000 mS in 5 mS increments
Forced Disconnect	
length	850 mS default, 0 - 2000 mS in 5 mS increments
delay	1.2 S to 30 S in 5 mS increments
Call Progress Tones	Tone levels are referenced to selected impedance. Single or dual frequencies from 10 to 1000 Hz, 1 Hz resolution (unless otherwise noted) Amplitude range is -6 to -60 dBm
Audible Ringback	440 Hz and 480 Hz \pm 1 Hz@ -19 \pm 1 dBm per tone (default), 10 Hz to 1000 Hz in 1-Hz increments, -6 dBm to -60 dBm per tone in 1-dBm increments

Dial Tone 1 and/or Tone 2	350 Hz and 440 Hz \pm 1 Hz @ -13 \pm 1 dBm per tone (default) 10 to 1000 Hz in 1-Hz increments, -6 dBm to -60 dBm per tone in 1-dBm increments
Busy Tone	440 Hz and 620 Hz \pm 1 Hz @ -24 \pm 1 dBm per tone (default) 10 Hz to 1000 Hz in 1-Hz increments, -6 dBm to -60 dBm per tone in 1-dBm increments

Call Progress Tones (continued)

Reorder Tone 1 and 2	480 Hz and 620 Hz \pm 1 Hz @ -24 \pm 1 dBm per tone (default) 10 to 1000 Hz in 1-Hz increments, -6 dBm to -60 dBm per tone in 1-dBm increments
Special Test Tone	1004 Hz \pm 1 Hz @ -24 \pm 1 dBm (default) 10 to 3000 Hz in 1-Hz increments, 0 dBm to -60 dBm per tone in 1-dBm increments
SIT	950, 1400, 1800, Hz @ -24 dBm (default) 10 - 2000 Hz in 1-Hz increments -6 dBm to -60 dBm in 1-dBm increments
On/Off duration	0 - 1 S in 5-mS increments
Number Unobtainable tone	950 + 1400 Hz @ -24 dBm @ 330 mS on/ 5 mS off/330 mS on/5 mS off rate (default) 0 to 2000 Hz in 1-Hz increments - 6 dBm to - 60 dBm in 1-dBm increments 0 to 10 S in 5-mS increments
Tone output options	Disabled, Tone1, Tone1 + Tone 2, or Tone1 x Tone2

Dialing Characteristics

Rotary Detection	8 - 22 PPS
percent break range	40 mS/60 mS make/break ratio (US, Germany, Sweden, etc.) 33 mS/67 mS make/break ratio (UK, France, Ireland, etc.)
min break time	18 mS
max break time	100 mS
min make time	9 mS
max make time	75 mS
interdigit time	300 mS minimum
DTMF Detection	
frequency accept	\pm 1.5% \pm 2 Hz
frequency reject	\pm 3.5%
tone on time	40 mS minimum
tone off time	40 mS minimum
amplitude	0 to -25 dBm composite and 6 dBm or less twist + 5 to 0 dBm composite and 3 dB or less twist

Caller ID

FSK tone level	-15 dBm per tone (default), -10 to -60 dBm in 1-dBm increments
FSK low frequency (tone1)	1200 Hz (default), 1100 - 1400 Hz in 1-Hz increments
FSK high frequency(tone2)	2200 Hz (default), 2000 - 2300 Hz in 1-Hz increments
CAS tone level	-15 dBm per tone (default) - 6 to 60 dBm in 1-dBm increments
CAS tone 1	2130 Hz (default), 10 - 3000 Hz in 1-Hz increments
CAS tone 2	2750 Hz (default), 10 - 3000 Hz in 1-Hz increments

Caller ID (continued)

CAS Tone Duration	80 mS (default), 70 to 90 mS in 5-mS increments
Wait for ACKnowledgement	160 mS (default), 100 - 300 ms in 5-mS increments
VMWI	See Caller ID for FSK info
OSI	0 - 5 S in 5-mS increments

Call Waiting

Tone 1	440 Hz (default) 10-1800 Hz in 1-Hz increments
Tone 2	disable (default), 10-1800 Hz in 1-Hz increments
Output level	-13 dBm (default), - 6 dBm to -60 dBm in 1-dB increments
Cadence	
on time	300 mS (default), 0 - 1.5 S in 5-mS increments
off time	0 mS (default), 0 - 1.5 S in 5-mS increments
leading blank	50 mS (default) 5 - 100 mS in 5-mS increments
trailing blank	50 mS (default), 5 - 100 mS in 5-mS increments

Metering Tones

12 or 16 kHz
0 - 5 VRMs in 100-mV increments
0 - 10 S on/off timing in 5-mS increments

Signal Level Measurement

Accuracy	± 1 mVRMS + 5% of value Accuracy over range from 400 to 3000 Hz Value time averaged over 100 ms reported approximately every second to the TLE-PC software program.
----------	---

Echo

Time	Selectable from 0 to 100 ms in 125- μ S increments
Level	60 dB (default), 4 - 60 dB in 1-dB increments
Level Accuracy	Maintained within ± 1 dB of setting

Satellite Delay

0 - 1000 mS in 125- μ S increments
--

White Noise

Source Broadbanded over 300 to 3400 Hz range (no C message weight)
 Level Accuracy ± 2 dB for values from 20 to 85 dBm

Audio Monitor Port

Connector 3.5 mm audio plug
 Output impedance 600 Ω
 Frequency response 300 - 3400 Hz
 Frequency gain 100 mVRMS ± 1 dB out into a 600 Ω load when a 200 mVRMS signal is injected into T&R
 Gain is unity into a high impedance load

Voice Messages

Stored in 8 kHz 8 bit μ -law WAV format
 Up to 4 messages, 8 seconds total in 0.5 S blocks

Temperature Range

Operating 0° C to +40° C
 Storage -40° C to +55° C

Humidity

Maximum humidity is 85% non-condensing

Altitude

Up to 2,000 meters

Regulatory

US/Canada
 FCC Part 15, Class A Complies
 Canada CISPR 22, Class A Complies
 UL 3111-1 Complies
 CSA C22.2 No. 1010-1 Complies

Europe

EN55022 Conducted & Radiated Emissions
 EN61000-3-2/3 Harmonic Emissions and Voltage Fluctuations
 EN61010 European Safety Requirements for Electrical Equipment for Measuring, Control, and Lab use.
 IEC 1000-4-2 Electrostatic Discharge Susceptibility (ESD)
 IEC 1000-4-3 Radiated Immunity
 IEC 1000-4-4 Electrical Transients

Mechanical Specifications

Dimensions 10.0" W x 13.2" D x 2.8" H
 Weight 7 lbs maximum

Appendix: Glossary

Some terms in this glossary were defined with the assistance of Newton's Telecom Dictionary. To order a copy, call 1-800-LIBRARY or write to: Telecom Library Inc., 12 West 21 Street, New York, New York 10010.

2500 set

The standard single-line touchtone desk telephone.

ACK

Shorthand term for the DTMF ACKnowledgement issued by a CPE device to request sending of the FSK Caller ID information

ADSI

Analog Display Services Interface. Defines a protocol on the flow of information between something (a switch, a server, a voice mail system, a service bureau) and a subscriber's telephone, PC, data terminal or other communicating device with a screen.

AST

Advanced Screen Telephony, see ADSI.

Busy Tone

A signal generated by the Central Office indicating that the line you are calling is busy.

Cadence

In voice processing, cadence is used to refer to the pattern of tones and silence intervals generated by a given audio signal. Examples are busy and ringing tones. A typical cadence pattern is the US ringing tone, which is two seconds of tone followed by four seconds of silence. Some other countries, such as the UK, use a double ring, which is two short tones within about a second, followed by a little over two seconds of silence.

Call Progress Tone

A tone sent from the switch to tell the caller of the progress of the call. Examples are audible ringing, re-order, busy, timing, etc.

Call Progress Tone Programming

Call progress tones may be single or dual frequencies with individually adjustable amplitudes. With a selection of "Single Tone" the system will only generate the first tone. With a selection of "Tone 1 and Tone 2" the system will generate both tones with the specified frequencies and amplitudes. With a selection of "Tone 1 X Tone 2" the system will generate Tone 1 modulated by Tone 2. In this implementation only the fundamental and upper side tone are generated, both at the amplitude programmed for Tone 1.

Call Waiting

Call Waiting is a feature of phone systems that lets you know someone is trying to call you.

Caller ID

Information about who's calling and/or their phone number is passed to your phone and is displayed on special Caller ID equipment.

CAS

CPE Alerting Signal - Bellcore term for tone used to alert CPE equipment of Call Waiting, asking for ACKnowledgement prior to sending Caller ID.

CE

Customer Equipment, see CPE

CEAS

Customer Equipment Alerting Signal, see CAS.

CID

See Caller ID.

CLIP

Calling Line Identification Presentation, see Caller ID.

C.O.

Central Office, a term used to describe the central location of switching equipment.

CPE

Customer Premise Equipment. Telephone products that reside at the customer location.

DDN

Dialable Directory Number. The number that the called party is required to dial to return a call to the calling party.

DIT

Display Information Transfer

DT-AS

Dual Tone Alerting Signal, see CAS.

DTMF

Dual Tone Multi Frequency. The technical term for touchtones; a combination of two tones.

ETSI

European Telecommunications Standards Institute, Central Office

Telephone company facility where subscribers lines are joined to switching equipment for connecting other subscribers to each other, locally and long distance. (Also called CO.)

CIDCW

Caller ID in Call Waiting - Bellcore term for Caller ID sent during an active call. Also known as Type 2 Caller ID.

dB

The decibel is a unit measurement used to express the ratio between two signals.

dBm

Decibel measurements compared to a 1 milliwatt signal referenced to a 600 ohm or 900 ohm load.

dBm

Decibel measurements compared to a Reference Noise. The Reference Noise level is -90 dBm = 0 dBm.

DTMF

Also called touchtone. Dual-tone multi-frequency. Push-button telephone signaling.

DSCWID

Spontaneous Call Waiting with ID and Disposition. Disposition is the ability of a screen phone to perform certain actions regarding the waiting call, such as play a voice message, send to voice mail, conference and others. Also known as Type 3 Caller ID.

Forced disconnect

Forced Disconnect is a method used by the telephone company to clear a line. When the called party goes on-hook, the Central Office returns an open (that is, drops loop current) of at least 800 mS to the calling party. This is also known as Calling Party Control (CPC), or Cutoff On Disconnect (COD), or Disconnect Supervision.

FSK

Frequency Shift Keying - A modulation technique that defines bits 0 and 1 as different frequencies for use in analog data transmissions.

Ground start

One of two types of switched telephone lines (outside lines) typically leased from telephone companies, the other type being loop start. A ground start telephone line initiates an outgoing telephone line seizure by applying a local resistance up to 550 ohms from ground to the tip conductor.

IRA

International Reference Alphabet.

Key Telephone System

A telephone system in which the telephones have multiple buttons that permit a user to select outgoing or incoming Central Office phone lines directly.

LE

Local Exchange, another name for Central Office, see C.O.

Line Seizure

Condition of the telephone line when loop current is being drawn by CPE

Line Reversal

see Polarity Reversal

Loop current

When a modem, telephone or fax card (etc.) seizes the line (i.e. completes the connection between tip and ring terminals of the telephone cable) current flows from the positive battery supply in the telephone central office, through the twisted pair in the loop, through the card (or phone) and back to the central office negative terminal where it is detected, showing that this telephone or telephone device is off hook. The fax card or modem can detect problems such as disconnects, shutting down the connection or a busy signal.

Loop start

One of two types of switched telephone lines (outside lines) typically leased from telephone companies, the other type being ground start. A loop start telephone line is seized by connecting a low resistance between the tip and ring (both wires) of the telephone line. This occurs whenever a telephone or modem goes off-hook. If you need to find out if a line is loop start, call the telephone company.

Off-hook

The telephone is in an off-hook state when the handset is removed from the cradle. A modem or other device is off-hook when it answers a call or when it seizes a line to initiate a call.

On-hook

a condition when the CPE is connected to a line and is not drawing loop current

Mark

Logical 1 or Symbol 1, equivalent to the lower of the two frequencies used in FSK signaling

MDMF

Multiple Data Message Format. A Caller ID transmission scheme that consists of a Message Header and a Message Body containing parameter messages. Generic description is Name + Number Transmission.

OSI

Open Switch Interval, a time when the DC battery is removed from Tip and Ring

Polarity Reversal

A line condition where the battery polarity is reversed from its current state

Public Switched Telephone Network (PSTN)

Refers to the worldwide voice telephone network accessible to those with telephones and access privileges. Also known as PTN, Public Telecommunications Network.

Reorder Tone

In North America the reorder tone that sounds like the busy signal, but is twice as fast. It indicates that all switching paths are busy.

Ringback

The sound you hear when you are calling someone else's phone. The tone you hear is generated by a device at the central office and may not be synchronized to the sound the phone at the other end is emitting - or not emitting.

RP-AS

Ringling Pulse Alerting Sequence. A short ring burst.

SAS

Subscriber Alerting Sequence, also known as Call Waiting Tone, this is an audible tone issued to a Called Party indicating a Waiting Call.

SDMF

Single Data Message Format. A Caller ID transmission that consists of a Message Header and a Message Body. Generic description is Number only Transmission.

Space

Logical 0 or Symbol 0, equivalent to the higher of the two frequencies used in FSK signaling

TAS

TE Alerting Signal, consists of either DT-AS, RP-AS, or a line reversal followed by a DT-AS

TE

Terminal Equipment - see CPE

TE-ACK

Terminal Equipment Acknowledgement - see ACKStuttered Dial Tone

Stuttered Dial Tone is a special dial tone consisting of an initial cadenced sequence (typically 10 tone bursts) followed by continuous tone. This is normally issued to notify a user that they have a voice mail message waiting.

SAS

Subscriber Alerting Signal - Bellcore term for Call Waiting Tone.

SCWID

Spontaneous Call Waiting with ID (Caller ID) - Northern Telecom term - same as CIDCW.

Type I Caller ID

This is a one way transmission (on-hook) that is normally number or name and number delivery after the first power ring and before the second ring.

Type II Caller ID

This is an off-hook transmission of Caller ID known as CIDCW - Caller ID in Call Waiting or SCWID - Spontaneous Call Waiting with Caller ID.

Type III Caller ID

This is an interactive off-hook sequence know as DSCWID, ADSI, & AST.

VMWI - Visual Message Waiting Indication

An on-hook FSK transmission used to turn on a visual indicator of a Caller ID adjunct or screen telephone to initiate messages in a CO based voice mailbox. Stuttered Dial Tone normally accompanies this feature for those users who do not have a visual indicator.

Index

2

2x2 port operation, 30

4

4 Port operation, 30

A

Acknowledge - CIDCW
TLE-ICID, 81

Active Configuration, 10, 11, 30
using DTMF, 10
using the serial port, 11

ADSI, 22

TLE-ICID, 71
Type III Caller ID, 22

Advanced Emulation Software Module (TLE-ADV), 36

Alerting Sequence
TLE-ICID, 69, 76

Alternate Voice Message, 14, 34

Application Guide
TLE-ADV, 36
TLE-INTL, 39

Attenuation
Recorded Messages, 15
Satellite Delay, 37

Audio

Attenuation, 15
Line Monitor, 14
Recorded Messages, 14
dial access, 14
invalid number, 14
on disconnect, 14

Australia defaults
TLE-ICID, 70, 90
TLE-INTL, 45, 46

Austria defaults
TLE-INTL, 47

B

Basic Calling Operation, 9

Belgium defaults
TLE-INTL, 48

Bellcore
TLE-ICID, 75, 77

Bellcore Plus

TLE-ICID, 75, 78, 79

Bibliography

TLE-ADV, 35
TLE-BASE, 35
TLE-ICID, 102
TLE-INTL, 39

Brazil defaults

TLE-INTL, 49

Busy

Phone Number, 29
Tone, 15
cadence, 15
levels and frequencies, 15

C

Cadence

Dial Tone, 24
TLE-ICID, 88

Call Setup Message Components, 77

Call Waiting, 16
Cadence, 17
leading blank, 17
trailing blank, 18

Cancel, 16
TLE-ICID, 76, 86
TLE-INTL, 42
Tone Levels and Frequencies, 17

Type, 17
TLE-ICID, 73
with Caller ID Disabled, 16

Call Waiting Timing

TLE-ICID, 88

Caller ID

ADSI, 22
After Every Ring, 19
TLE-ADV, 36

CAS Tone, 21
Configuration
TLE-ICID, 72

FSK Tone, 21
FSK Transmission
TLE-ICID, 71

Group 1 Name, 20
Minimum Ring Off Time, 19
Mode, 20

Open Switch Interval, 22

Out of Area, 70

Private, 70

Select Name & Number, 20

Sequence, 19

Time, 19

Telephone Line Emulator User's Manual

- Timing Parameters-TLE-ICID, 73
 - DTMF, 73
 - FSK, 74
 - TLE-ICID, 69, 75, 86
 - TLE-INTL, 42
 - Transmissions
 - DTMF - TLE-ICID, 71
 - FSK - TLE-ICID, 71
 - Type I Signaling
 - TLE-ICID, 69
 - Type II Signaling
 - TLE-ICID, 69
 - Visual Message Mode, 20
 - Visual Message Waiting, 18
 - Wait for Acknowledgement, 21
 - Caller ID and Call Waiting Modes, 75
 - Caller ID Standards
 - Bellcore, 75
 - Bellcore Plus, 75
 - ETSI DTMF, 75
 - ETSI FSK, 75
 - Everything, 75
 - Caller ID/Call Waiting - TLE-ICID, 86
 - Caller ID and Call Waiting Modes
 - call waiting, 76
 - Caller ID, 75
 - Caller ID and CIDCW Components and Sequence
 - MDMF, 77
 - SDMF, 76
 - Caller ID Miscellaneous Parameters
 - acknowledge - CIDCW, 81
 - extension for network operator, 81
 - network message status, 81
 - user defined parameters, 81
 - Phone Number Prefix and Group Selections
 - calling party name, 82
 - Timings
 - cadence, 88
 - call waiting timing, 88
 - CAS duration, 88
 - DTMF/FSK to ring, 87
 - dual tone duration, 88
 - dual tone to FSK, 87
 - line reversal to DTMF, 87
 - line reversal to dual tone, 87
 - minimum ring off time, 88
 - off-hook mark time, 87
 - on-hook channel seizure, 87
 - on-hook mark time, 87
 - OSI duration, 88
 - OSI to FSK, 87
 - repeat, 89
 - ring burst alerting signal, 87
 - ring to DTMF/FSK, 86
 - wait for acknowledge, 88
 - Calling Party Name
 - TLE-ICID, 82
 - Canada defaults
 - TLE-ICID, 70
 - TLE-INTL, 68
 - Cancel Call Waiting, 16
 - CAS Duration
 - TLE-ICID, 88
 - CAS Tone
 - Caller ID, 21
 - TLE-ICID, 69
 - CAS/Dual Tone Alerting
 - TLE-ICID, 84
 - Checksum Error, 18, 19
 - TLE-ICID, 71, 72
 - China defaults
 - TLE-INTL, 50
 - Cleaning, 116
 - Clone, 31
 - Port Configuration, 30
 - Complex Impedance
 - TLE-INTL, 45
 - TLE-TEST, 104
 - Conference Type
 - Miscellaneous, 27
 - Configuration Set, 11
 - Configuring the TLE, 10
 - Confirmation Tones
 - Miscellaneous, 26
 - Copy Configuration, 12
 - Copy Line, 12
 - Country Default Settings, 45
 - CPE Alerting Sequence
 - TLE-ICID, 69, 84
- ## D
- Date and Time
 - TLE-ICID, 72
 - DC Signaling, 22
 - Forced Disconnect, 23
 - Hook Flash Detect, 23
 - Line Reversal, 23
 - On/Off-hook Detect Times, 23
 - Delay Before Dial Tone, 25
 - Delay Before Second Dial Tone, 25
 - Denmark defaults
 - TLE-INTL, 51
 - Dial Access Voice Message, 14, 34
 - Dial Tone, 24, 30
 - Cadences, 24
 - Delay Before, 25
 - Delay Before Second, 25
 - Levels and Frequencies, 24
 - Test Number, 29
 - Disconnect Treatment

- Miscellaneous, 26
- Disconnect Voice Message, 14, 34
- DTMF Generation
 - TLE-ICID, 85
 - TLE-TEST, 105
- DTMF Mode
 - TLE-ICID, 84
- DTMF Timing Parameters
 - TLE-ICID, 73
- DTMF Transmission
 - TLE-ICID, 71
- DTMF/FSK to Ring
 - TLE-ICID, 87
- Dual Tone Alerting Sequence
 - TLE-ICID, 69
- Dual Tone Duration (DT-AS)
 - TLE-ICID, 88
- Dual Tone to FSK
 - TLE-ICID, 87

E

- Echo
 - TLE-ADV, 36
- Edit Configuration, 10, 12, 30, 40
- Error Messages
 - Audio Related, 112
 - Communication Port Errors, 113
 - Configuration, 111
 - Defaults, 111
 - File Errors, 114
 - Miscellaneous, 112
 - On power-up, 110
 - Telephone Wiring Variants, 114
 - Upgrade, 113
- ETSI DTMF
 - TLE-ICID, 75, 84
- ETSI FSK, 75, 78, 80
- Everything
 - TLE-ICID, 75
- Extension for Network Operator
 - TLE-ICID, 81

F

- Figures
 - Timing Diagrams, 73
 - Type I - CID or CLIP Sequence of Events, 70
 - Type II - Caller ID in Call Waiting sequence, 70
 - UK Phone Wiring Diagram, 114
- Finland defaults
 - TLE-INTL, 52
- Forced Disconnect
 - DC Signaling, 23
 - Delay, 23

- Length, 23
- France defaults
 - TLE-ICID, 70, 92
 - TLE-INTL, 53
- FSK
 - Timing Parameters
 - TLE-ICID, 74
 - Tone
 - Caller ID, 21
 - TLE-ICID, 84

G

- Germany defaults
 - TLE-ICID, 70, 94
 - TLE-INTL, 45, 54
- Getting Started, 4
- Glossary, 122
- Greece defaults
 - TLE-INTL, 55
- Group 1 Name, 20

H

- Hook Flash Detect
 - DC Signaling, 23
- Hunt Mode
 - Miscellaneous, 28

I

- Impairments
 - TLE-ADV, 36
 - echo, 36
 - satellite delay, 37
 - white noise, 36
- Impedance
 - Complex, 45
 - Loop Parameters, 25
- Independent switch operation
 - Ports 2 & 4, 30
- India defaults
 - TLE-INTL, 56
- Information Code
 - TLE-ICID, 85
- Informational and Error Messages, 111
- International Software Module (TLE-INTL), 39
- Introduction
 - TLE-ICID, 69
- Invalid Number Response
 - Miscellaneous, 28
- Invalid Number Voice Message, 14, 34
- Ireland defaults
 - TLE-INTL, 57
- Italy defaults
 - TLE-INTL, 58

J

Japan defaults
TLE-INTL, 59

K

Korea defaults
TLE-INTL, 60

L

Line Receive Attenuation
Loop Parameters, 26
Line Reversal
DC Signaling, 23
Line Reversal to DTMF
TLE-ICID, 87
Line Reversal to Dual Tone
TLE-ICID, 87
Loop Current
Loop Parameters, 26
Loop Parameters, 25
Impedance, 25
Line Receive Attenuation, 26
Loop Current, 26
TLE-INTL, 45

M

Maintenance, 116
cleaning, 116
servicing, 116
MDMF, 69
Call Setup Message Components, 77
Bellcore, 77
Bellcore Plus, 78
ETSI FSK, 78
Message Waiting Message Components, 79
Bellcore or Bellcore Plus, 79
ETSI FSK, 80
TLE-ICID, 77
Message Waiting
TLE-ICID, 75
Metering Tones
TLE-ADV, 37
TLE-INTL, 43
Minimum Ring Off Time
Caller ID, 19
TLE-ICID, 88
Miscellaneous, 26
Conference Type, 27
Confirmation Tones, 26
Disconnect Treatment, 26
Hunt Mode, 28
Invalid Number Response, 28
Network Delay, 28

Off-hook Mode, 27
Rotary Dial Only, 27
Test Tones, 27

N

Netherlands defaults
TLE-ICID, 70, 96
TLE-INTL, 61
Network Delay
Miscellaneous, 28
Network Message Status
TLE-ICID, 81
No Ringing CID
TLE-ICID, 75
Normal Caller ID
TLE-ICID, 72, 84
Normal CID Delivery
TLE-ICID, 71
Norway defaults
TLE-INTL, 62
Not Associated with Ringing Caller ID
TLE-ICID, 86
Number Unobtainable
TLE-INTL, 43
Screen, 43

O

Off-hook Detect Times
DC Signaling, 23
Off-hook Mark Time
TLE-ICID, 87
Off-hook Mode
Miscellaneous, 27
On/Off-hook Detect Times
DC Signaling, 23
On-hook Channel Seizure
TLE-ICID, 87
On-hook Mark Time
TLE-ICID, 87
Open Switch Interval
Caller ID, 22
Operational Screens, 14
Audio, 14
Busy Tone, 15
Dial Tone, 24
Loop Parameters, 25
Miscellaneous, 26
Phone Numbers, 28
Reorder, 31
Ringing, 32
Special Information Tones, 33
Voice Messages, 34
Options, 1
Ordering information, 117

OSI Duration
 TLE-ICID, 88
 OSI to FSK
 TLE-ICID, 87
 Out of Area, 18, 19
 TLE-ICID, 71, 72, 84
 Overview, 1
 TLE-ICID, 69

P

Phone Number, 82
 Phone Numbers, 28
 Busy, 29
 Dial Tone, 29
 Reorder, 29
 Revert to Dial Tone, 29
 Ringback, 29
 Screen, 28
 Special Test Tone, 30
 Stuttered Dial Tone, 30
 Port Configuration, 30
 Power up the TLE, 5
 Private, 18, 19
 TLE-ICID, 71, 72, 84
 Product Registration, 4
 Programming
 TLE-ICID, 74
 Programming Guide
 TLE-INTL, 40

R

Recorded Messages, 14
 References
 TLE-ADV, 35
 TLE-BASE, 35
 TLE-ICID, 102
 TLE-INTL, 39
 Reorder, 31
 Cadence, 31
 first, 31
 second, 32
 Phone Number, 29
 Repeat
 TLE-ICID, 89
 Repeat Caller ID After Every Ring, 86
 Reset to Defaults, 10, 40, 74
 Return Procedures, 116
 Revert to Dial Tone
 Phone Numbers, 29
 Revision History, 106
 Ring Burst Alerting Signal
 TLE-ICID, 87
 Ring to DTMF/FSK
 TLE-ICID, 86

Ringback
 Phone Numbers, 29
 Ringing, 33
 Ringing, 32
 Cadence Group, 33
 Lines, 32
 Ringback, 33
 Rotary Dial Only
 Miscellaneous, 27
 Rotary Dialing
 TLE-ADV, 36
 TLE-INTL, 39

S

SAS, 16
 TLE-ICID, 69, 73, 83
 Satellite Delay
 TLE-ADV, 37
 Screens
 Caller ID/Call Waiting
 Caller ID and Call Waiting Modes, 75
 Caller ID and Call Waiting Tones, 83
 Caller ID and CIDCW Components and
 Sequence, 76
 Caller ID Miscellaneous Parameters, 80
 DTMF CID Parameters, 84
 Phone Number Prefix and Group
 Selections, 82
 Timings, 86
 SCWID, 16
 SDMF
 TLE-ICID, 69, 76
 Select Name & Number, 20
 Setting up the TLE, 5
 Installing Software, 5
 Signal Level Measurement
 TLE-ADV, 38
 Singapore defaults
 TLE-ICID, 70, 97
 TLE-INTL, 63
 Software installation, 5
 Windows 3.1, 3.11, 6
 Windows 95 or later, 5
 Software Key, 36, 39
 Spain defaults
 TLE-INTL, 64
 Special Information Tones, 33
 Special Test Tone
 Phone Number, 30
 Standard Unit Features (TLE-BASE), 1
 Stuttered Dial Tone
 Phone Number, 30
 Sweden defaults
 TLE-ICID, 70, 98
 TLE-INTL, 45, 65

Telephone Line Emulator User's Manual

Sweep Tone
TLE-TEST, 105
Switzerland defaults
TLE-INTL, 66

T

Technical Assistance, 116
Technical Specifications, 118
Test Numbers
 Busy, 29
 Dial Tone, 29
 Reorder, 29
 Ringback, 29
 Special Test Tone, 30
 Stuttered Dial Tone, 30
Test Tones
 Miscellaneous, 27
TLE
 Front and Rear Panel, 3
 Operation, 6
TLE-ADV, 2, 4, 18, 19, 39, 104, 107
 Caller ID After Every Ring, 36
 Echo, 36
 Impairments, 36
 Metering Tones, 37
 Rotary Dial Only, 36
 Satellite Delay, 37
 Signal Level Measurement, 38
 White Noise, 36
TLE-BASE, 10, 104
TLE-ICID, 2, 4, 12, 18, 42, 69
 Caller ID
 Configuration, 72
 DTMF transmission, 71
 FSK transmission, 71
 Normal, 72
 Checksum, 72
 Countries
 Australia, 70, 90
 Canada, 70
 France, 70, 92
 Germany, 70, 94
 Netherlands, 70, 96
 Singapore, 70, 97
 Sweden, 70, 98
 United Kingdom, 70, 99
 United States, 70, 101
 Date and Time, 72
 Introduction, 69
 Operation, 70
 Out of Area, 72
 Overview, 69
 Private, 72
 Programming, 74
TLE-INTL, 1, 4, 18, 25, 31, 34, 69, 104, 107

Caller ID/Call Waiting, 42

Countries

Australia, 45, 46
Austria, 47
Belgium, 48
Brazil, 49
Canada, 68
China, 50
Denmark, 51
Finland, 52
France, 53
Germany, 45, 54
Greece, 55
India, 56
Ireland, 57
Italy, 58
Japan, 59
Korea, 60
Netherlands, 61
Norway, 62
Singapore, 63
Spain, 64
Sweden, 45, 65
Switzerland, 66
United Kingdom, 45, 67
United States, 68
Country Settings, 40
Metering Tones, 43
Programming Guide, 40
Reset to Defaults, 40
TLE-TEST, 2, 4, 19, 107
 Complex Impedance, 104
 DTMF Generation, 105
 Sweep Tone, 105
Troubleshooting, 110
 Audio Related Error Messages, 112
 Communication Port Errors, 113
 Configuration Error Messages, 111
 Defaults File, 111
 Error Messages on Power-up, 110
 File Errors, 114
 Informational and Error Messages, 111
 Miscellaneous, 112
 Telephone Line Variants, 114
 Upgrade Error Messages, 113
Type I Signaling, 69, 71
 Alerting Sequences, 69
Type II Signaling, 69, 71
 Alerting Sequences, 69
Type III Caller ID, 71

U

United Kingdom defaults
TLE-ICID, 70, 99
TLE-INTL, 45, 67

United States defaults
 TLE-ICID, 70, 101
 TLE-INTL, 68
User Defined Parameters
 TLE-ICID, 81

V

Version 1.00, 106
Version 1.01, 106
Version 1.02, 106
Version 1.03, 107
Version 2.00, 25, 45, 107
Version 2.01, 107
Version 3.00, 25, 42, 45, 108
Version 3.01, 108
Version 3.02, 108
Version 3.03, 108
Version 3.04, 108
Version 3.05, 109

Visual Message Mode, 20
Voice Messages, 14, 34
 Alternate, 14, 34
 Dial Access, 14, 34
 Disconnect, 14, 34
 Invalid Number, 14, 34

W

Wait for Acknowledgement
 Caller ID, 21
 TLE-ICID, 88
Warranty, 116
White Noise
 TLE-ADV, 36
Windows 3.1, 3.11, 6
Windows 95 or later, 5